

**NEW** GLOBAL STANDARD VERTICAL MACHINING CENTER

# **DNM 4500·5700·6700<sup>4th</sup>**

**DNM 4500/L**

**DNM 5700/L**

**DNM 6700/L**

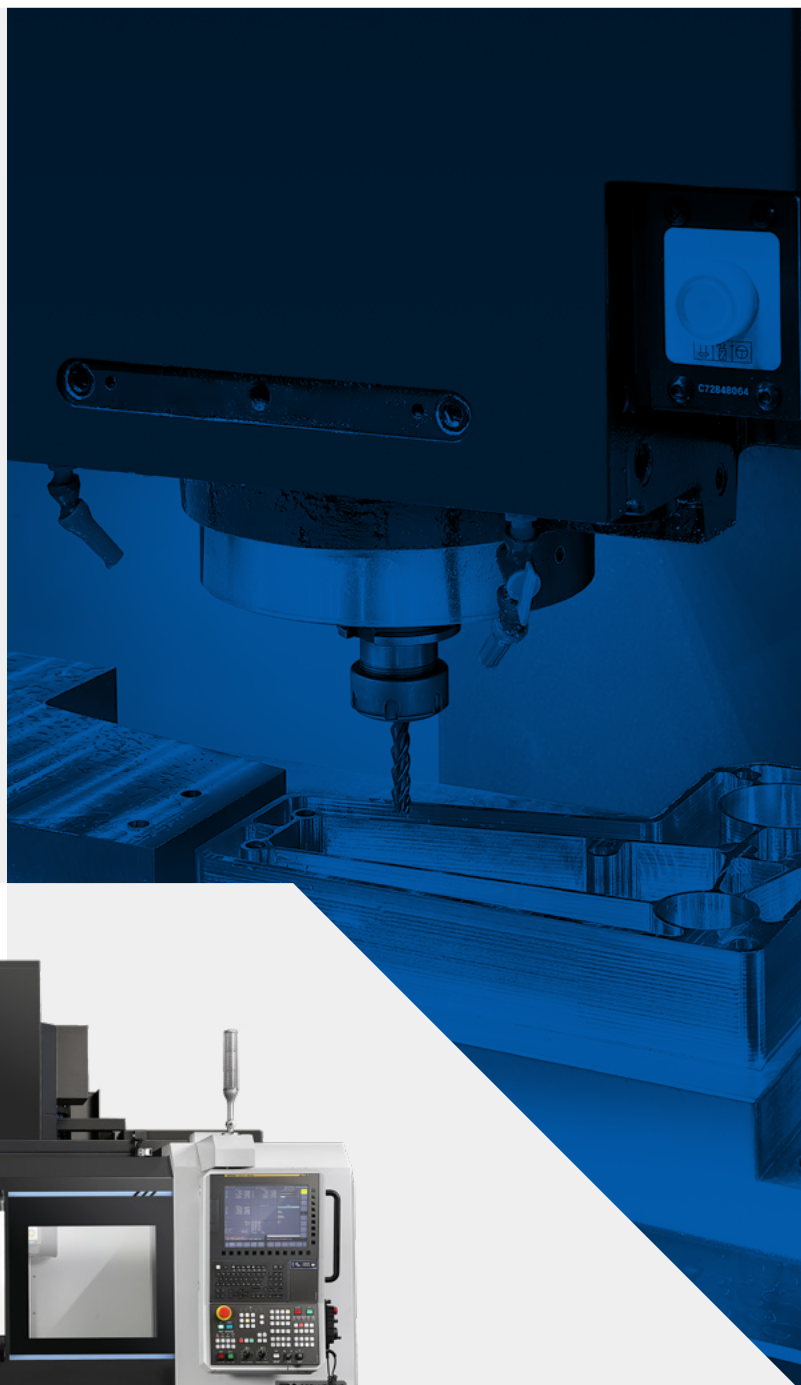

# NEW **DNM** 4500 · 5700 · 6700<sup>4th</sup>

DNM, which is used by many customers around the world, inherited the reputation of the first, second, and third generations and improved reliability in the '4th DNM', and applied grease lubrication to the spindle and each axis system as standard for eco-friendly operation. In particular, it has been developed with the goal of excellent productivity and best-in-class durability and rigidity, and has enhanced user convenience and enabled more efficient operation through the expansion of the L Series. Experience the 4th DNM, a Global Standard Machining Center that not only excels in performance but also considers quality, human-centered design, and environmental factors.

The 4th generation DNM is equipped with the maximum machining area, superior rapid performance, and productivity compared to competitors, ensuring precise and efficient machining. Additionally, it offers various options and convenient features, including a 15-inch touch screen.

## CONTENTS

### Product Overview

### Basic Information

- 04 Basic Structure
- 05 Spindle
- 05 Table
- 06 Tool Change System
- 06 Eco-Friendly
- 07 4<sup>th</sup> Generation DNM Enhancements
- 08 AWC Automation

### Detailed Information

- 09 Standard | Optional Specifications
- 10 Peripheral Equipment
- 11 FANUC i PLUS
- 12 EZ work
- 13 Convenient Operation
- 17 Power | Torque
- 19 Dimensions
- 25 Machine Specifications

### Customer Support Service

- 26 Why DN Solutions
- 27 Customer Support and Services
- 27 Global Network



**A HIGHLY VERSATILE VERTICAL MACHINING CENTER WITH THE LARGEST MACHINING ENVELOPE IN ITS CLASS**



**STANDARD DIRECT-COUPLED SPINDLE FOR HIGHER PRODUCTIVITY**



**AN ENVIRONMENTALLY-FRIENDLY MACHINE DESIGNED FOR STABLE AND EASY OPERATION**



- DNM is a Global Standard 3-axis Machining Center that has improved rapid and acceleration/ deceleration performance, and has the highest productivity compared to competitors.
- Compared to the previous model, various options are provided and user convenience is increased through EZ Work improvement.

- Improved axial thermal displacement by 2x compared to previous models, and ATC Shutter as standard to prevent chip penetration into the ATC.
- High-torque and high speed spindles are available for the machining of different materials.
- Higher productivity is achieved by reducing tool change times and by improving acceleration and deceleration rates.

- Thermal error compensation system supplied as standard optimizes machine accuracy by reducing the effects of heat build-up during extended periods of operation.
- A 15-inch iHMI touch screen is standard for easy machine operation, and a variety of convenience features are available.
- Grease lubrication for the axis roller guideways is a standard feature and helps reduce contamination.



# BASIC STRUCTURE

Designed with a highly stable and rigid structure, the new DNM series provides customers with machines with different Y-axis capabilities (from 450mm to 670mm), enabling the machining of a wider range of workpieces.

## Travel distance (X / Y / Z axis)

**DNM 4500**

**800 / 450 / 510** mm  
(31.5 / 17.7 / 20.1 inch)

**DNM 4500L**

**910 / 450 / 510** mm  
(35.8 / 17.7 / 20.1 inch)

**DNM 5700**

**1050 / 570 / 510** mm  
(41.3 / 22.4 / 20.1 inch)

**DNM 5700L**

**1300 / 570 / 510** mm  
(51.2 / 22.4 / 20.1 inch)

**DNM 6700**

**1300 / 670 / 625** mm  
(51.2 / 26.4 / 24.6 inch)

**DNM 6700L**

**1500 / 670 / 625** mm  
(59.1 / 26.4 / 24.6 inch)



DNM 6700

## Axis system

Environmentally-friendly grease lubrication is adopted as standard for all the axis feed systems, and roller-type LM guides are used to enhance rigidity.

## Rapid traverse rate (X / Y / Z axis)

**DNM 4500 / 5700 / 4500L / 5700L**

**42 / 42 / 36** m/min  
(1653.5 / 1653.5 / 1417.3 ipm)

**DNM 6700 / 6700L**

**36 / 36 / 30** m/min  
(1417.3 / 1417.3 / 1181.1 ipm)

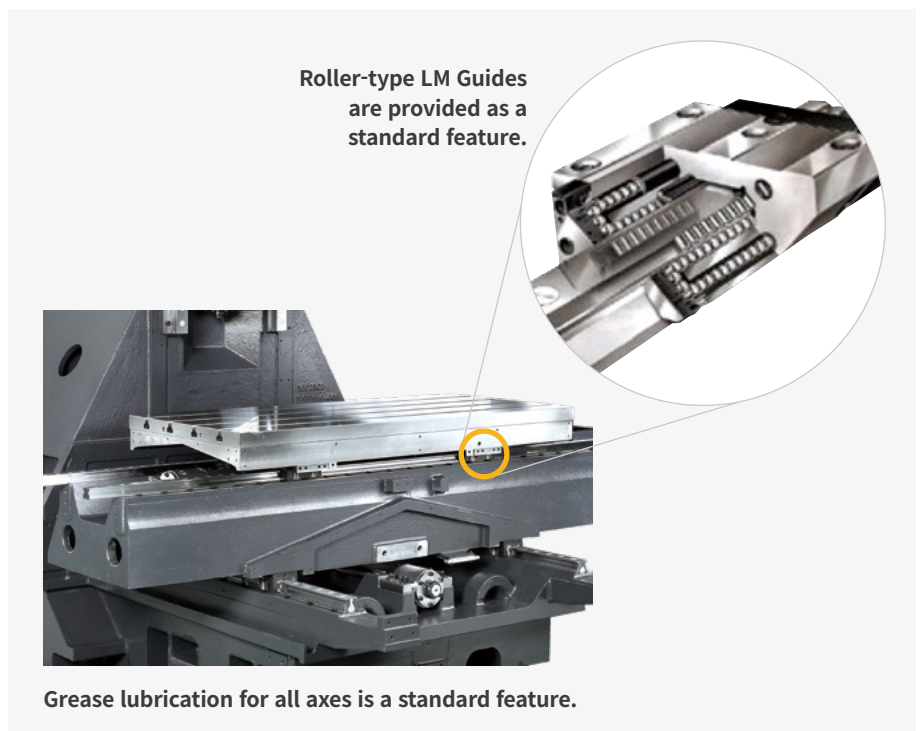

Roller-type LM Guides are provided as a standard feature.

Grease lubrication for all axes is a standard feature.

# SPINDLE

Directly-coupled spindles have been adopted as a standard feature to further reduce vibration and noise and enhance productivity, increase accuracy and improve the working environment. High-torque and high speed spindle options for machining different materials are available.

## Max. spindle speed

**8000** r/min  
{12000/15000 OPTION} r/min

## Max. spindle motor power

**18.5** kW (24.8 Hp)

## Max. spindle motor torque

**117.8** N·m (86.9 lbf-ft)  
(8000 r/min, 12000 r/min,  
15000 r/min)

**286** N·m (211.1 lbf-ft) OPTION  
(8000 r/min high torque version)

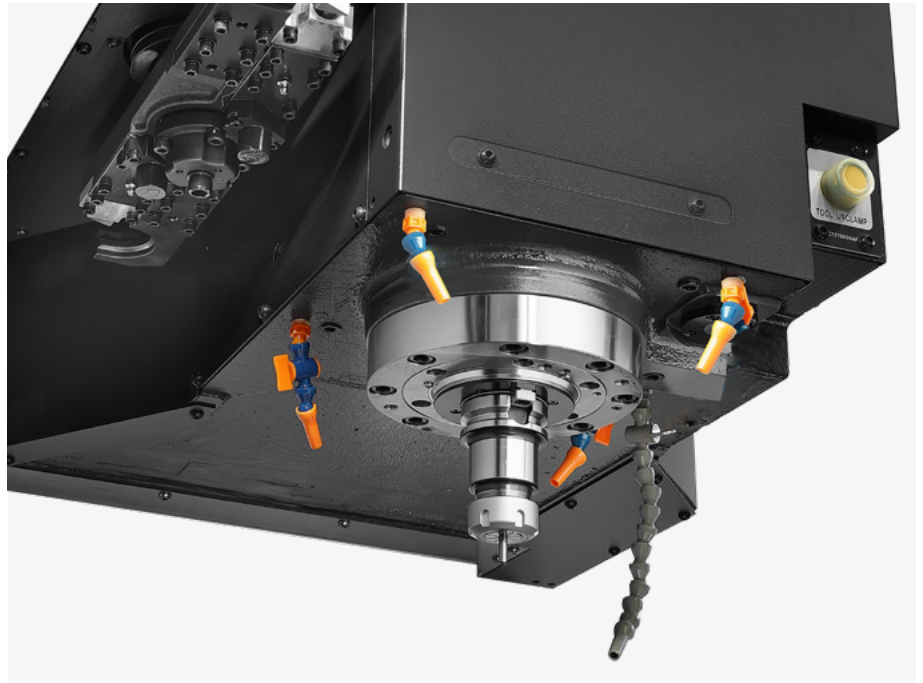

# TABLE

Increased table sizes and table load capacities are provided within the same floor space of the previous models.

## Table size

Model	A x B
<b>DNM 4500</b>	1000 x 450 mm (39.4 x 17.7 inch)
<b>DNM 4500L</b>	1050 x 450 mm (41.3 x 17.7 inch)
<b>DNM 5700</b>	1300 x 570 mm (51.2 x 21.3 inch)
<b>DNM 5700L</b>	1500 X 570 mm (59.1 x 21.3 inch)
<b>DNM 6700</b>	1500 x 670 mm (59.1 x 26.4 inch)
<b>DNM 6700L</b>	1600 X 670 mm (63.0 x 26.4 inch)

## Max weight on Table

**DNM 4500 / 4500L**      **DNM 5700 / 5700L**  
**600** kg                      **1000** kg  
(1322.8 lb)                      (2204.6 lb)

**DNM 6700 / 6700L**  
**1300** kg  
(2866.0 lb)

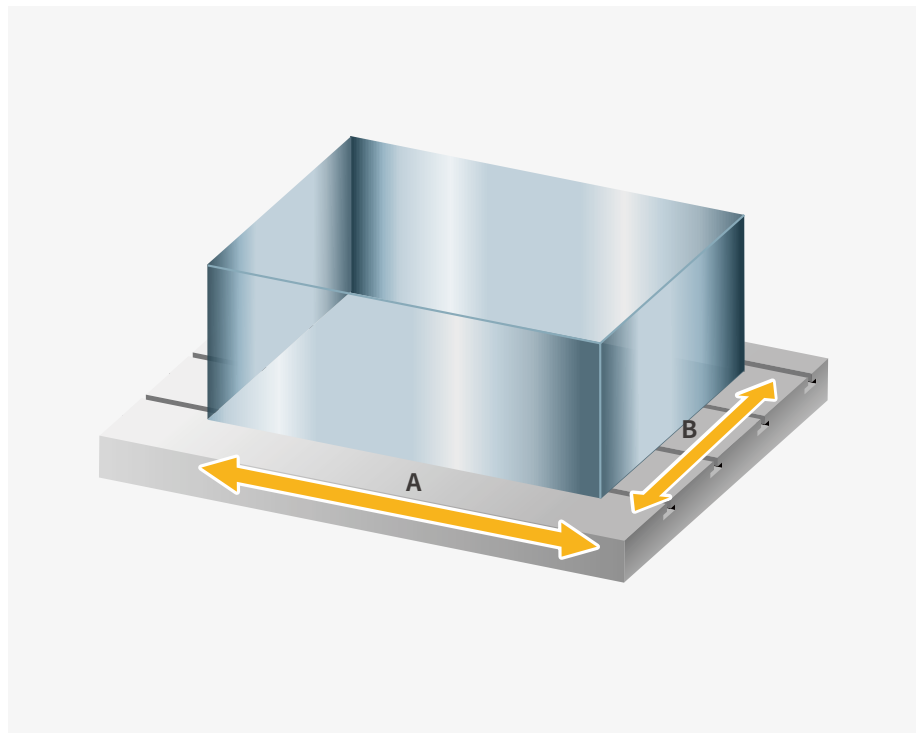

# TOOL CHANGE SYSTEM

Tool changers have been optimized to reduce non cutting times. The highly-reliable tool magazine can accommodate up to 30 tools as standard.

**Tool to Tool time**

**1.2 S**

**Chip to Chip\* time**

**4.1 S** (with ATC Shutter)

**3.2 S** (w/o ATC Shutter)

\* The Chip-to-Chip time has been tested in accordance with DN Solutions's strict testing procedures, but may vary depending on the user's operating conditions.

**Tool storage capacity**

**30** {40 / 60 OPTION} ea



## ECO-FRIENDLY

**Power consumption monitoring function**

- Suitable for power consumption management with standard power consumption monitoring function.



**High efficiency coolant pump**

- FLOOD : 1.8 ⇒ 1.1kW / 1.1 ⇒ 0.75kW
- Performance is maintained and energy consumption is reduced by using a high-efficiency motor.

**Productivity UP**

- Productivity improvement reduces processing time for the same item and energy consumption compared to competitors.

**Chip conveyor with inverter**

- Energy saving by optimizing the rotation speed according to the amount of chips.

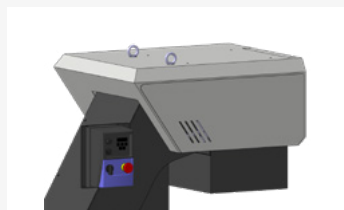

**GREASE lubrication**

- Optimization of oil usage by applying grease lubrication.



# NEW 4<sup>th</sup> GENERATION DNM' ENHANCEMENTS

DNM, the global standard 3-axis machining center, is a best-selling model that has increased user convenience and enhanced product performance and design. Introducing the strengths of the 4th generation DNM.

## Improved axis thermal displacement

X, Y : **2** x improvement Z : **1.3** x improvement

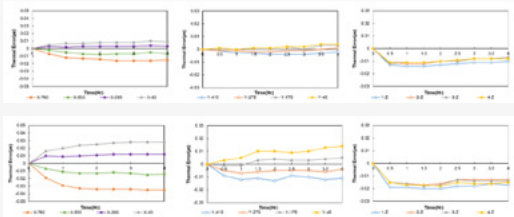

\* The above test results are based on our test standards and may vary depending on conditions (DNM 4500)

## Coolant tank capacity 20% up

Improved to reduce coolant shortage, replenishment cycle when using multiple coolant systems simultaneously.

DNM4500/L : 300 → **380/385L**

DNM5700/L : 345 → **430/440L**

DNM6700/L : 390 → **435/470L**

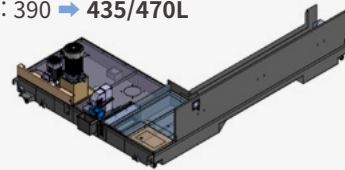

## Applying the Atc shutter standard

Prevent chip penetration into the ATC.

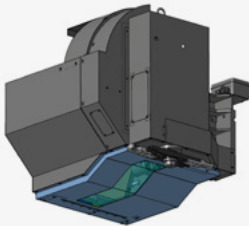

## EZ Work

Upgraded the design of the EZ WORK main screen by adding bookmarks and operation buttons.



## C/C speed adjustment and 20% more chip ejection space

Adjusting C/C speed by applying an inverter

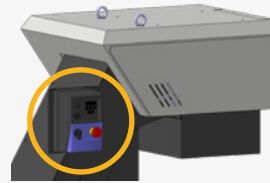

20% increase in CHIP exhaust space (Easier to eject large chips)

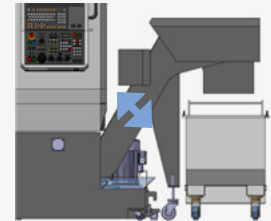

160(6.3) → **200mm (7.9 inch)**

## Round Type Flood Coolant

Expect better machining performance and longer tool life

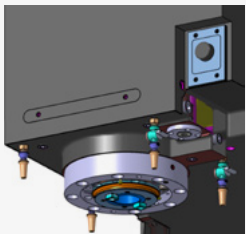

## Tool call function

A function that directly exchanges the tool to the spindle when the user inputs the desired tool number or magazine port number and calls the tool.

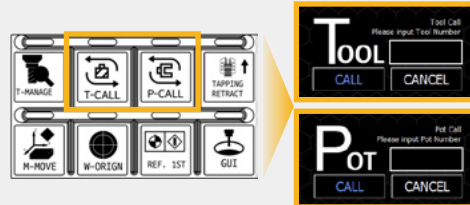

## Rear Tool Storage Options OPTION

(W/Tool Info Touch Screen)

- Applying a large door that is advantageous for tool storage
- Tool information touch screen\*

\* Tool Information Input

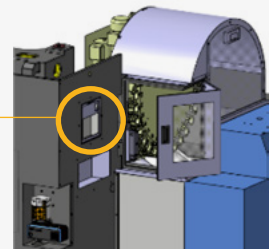

Applicable only to FANUC and HEIDENHAIN NC

## High Productivity

### Rapid

- DNM 4500 / 4500L / 5700 / 5700L  
X/Y/Z : 36/36/30 → **42/42/36** m/min  
(1653.5 / 1653.5 / 1417.3 ipm)
- DNM 6700 / 6700L  
X/Y/Z : 36/36/30 m/min  
(1653.5 / 1653.5 / 1417.3 ipm)

## Productivity : In DNM4500

	Non-cutting time	Cutting time	Run hours
Previous model	1min 47sec.	1min 22sec.	3min. 9sec.
New DNM series	1min 33sec.	1min 22sec.	2min. 55sec.
	Reduced by <b>13.1 %</b>		Reduced by <b>7.3 %</b>

\* The results, indicated in this catalogue, are provided as examples only. They may not always be achieved owing to different cutting and environmental conditions.

# AWC AUTOMATION

It can hold up to 40 processed items and provides a compact and optimal automation solution through an automatic workpiece exchange system. Additionally, an AWC READY PACKAGE is available to facilitate easy AWC automation retrofitting on-site.

## AWC, Multi-AWC OPTION

A compact automation system providing fast, reliable and high productivity workpiece change capabilities.

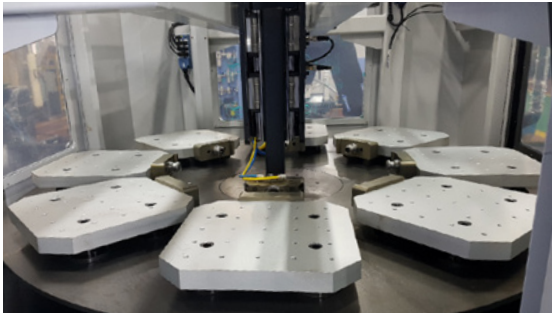

AWC

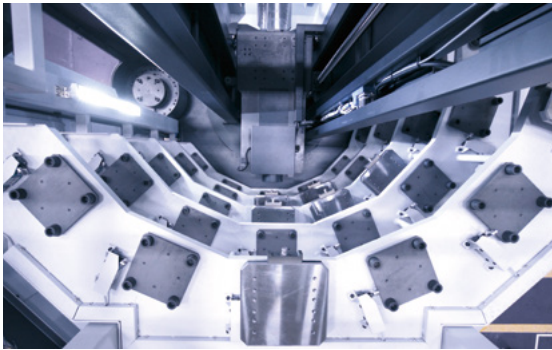

Multi-AWC



Description	Pallet size	No. of pallets	Max. workpiece dia. x height	Max. workpiece weight	Applicable model
AWC	250x250 mm (9.8x9.8 inch)	12ea	Ø300x350 mm (11.8x13.8 inch)	130 kg (286.6 lb)	DNM 4500 / 4500L / 5700 / 5700L / 6700 / 6700L
	350x350 mm (13.8x13.8 inch)	8ea	Ø400x350 mm (15.7x13.8 inch)	300 kg (661.4 lb)	DNM 4500 / 4500L / 5700 / 5700L / 6700 / 6700L
	400x400mm (15.7x15.7 inch)	6ea	Ø450x350 mm (17.7x13.8 inch)		DNM 4500 / 4500L / 5700 / 5700L / 6700 / 6700L
	500x500mm (19.7x19.7 inch)	4ea	Ø550x350 mm (21.7x13.8 inch)		DNM 5700 / 5700L / 6700 / 6700L
Multi-AWC	250x250mm (9.8x9.8 inch)	40ea (10x4-tier)	Ø300x350 mm (11.8x13.8 inch)	130kg (286.6 lb)	DNM 4500 / 4500L / 5700 / 5700L / 6700 / 6700L
	350x350mm (13.8x13.8 inch)	32ea (8x4-tier)	Ø400x350 mm (15.7x13.8 inch)	300 kg (661.4 lb)	DNM 4500 / 4500L / 5700 / 5700L / 6700 / 6700L
	400x400mm (15.7x15.7 inch)	28ea (7x4-tier)	Ø450x350 mm (17.7x13.8 inch)		DNM 4500 / 4500L / 5700 / 5700L / 6700 / 6700L
	500x500mm (19.7x19.7 inch)	24ea (6x4-tier)	Ø550x350 mm (21.7x13.8 inch)		DNM 5700 / 5700L / 6700 / 6700L

## Pallet storage-table configuration

Unit : mm (inch)

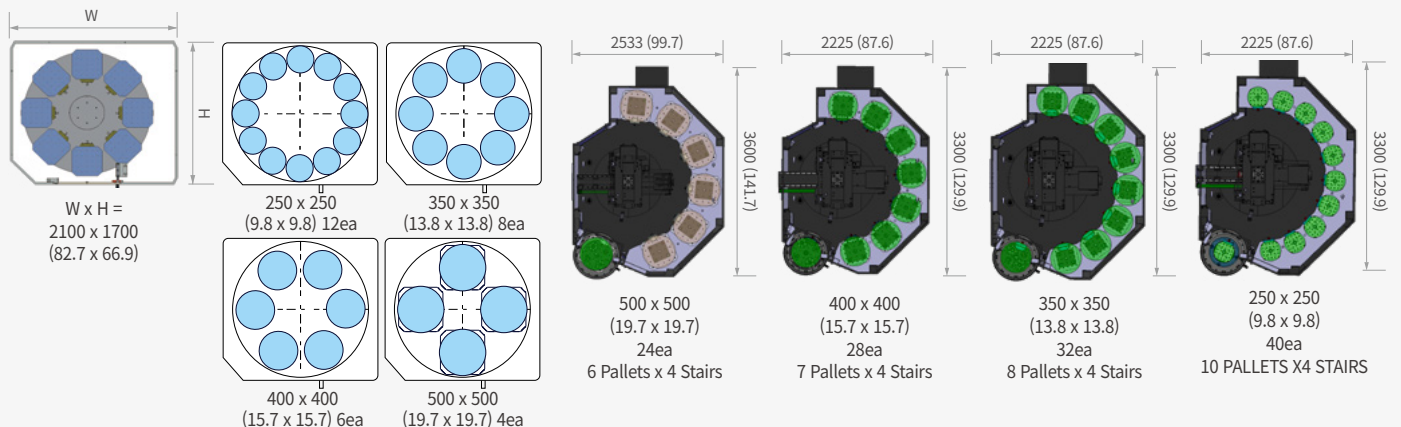

# STANDARD | OPTIONAL SPECIFICATIONS

Various optional features are available to meet customers' specific machining requirements and applications.

Description		Features	DNM 4500 / L	DNM 5700 / L	DNM 6700 / L	
Spindle	8000 r/min	18.5/11 kW, 117.8 N·m	●	●	X	
		18.5/15 kW, 117.8 N·m	X	X	●	
		15/11 kW, 286 N·m	○	○	○	
	12000 r/min	18.5/11 kW, 117.8 N·m	○	○	○	
	15000 r/min	18.5/11 kW, 117.8 N·m	○	○	○	
Magazine	Tool storage capacity	30 ea	●	●	●	
		40 ea	○	○	○	
	Rear tool storage****	30 ea	○	○	○	
		40 ea	○	○	○	
Tool shank type	BIG PLUS BT40	●	●	●		
	BIG PLUS CAT40	○	○	○		
	BIG PLUS DIN40	○	○	○		
Raised column	150 mm	○	○	○		
	200 mm	○	○	○		
	300 mm	○	○	○		
4 axis NC Rotary table	S-200F4-DS	○	○	○		
	S-250F8-DS	○	○	○		
	S-320F8-DS	X/○	○	○		
Coolant	FLOOD	0.16 MPa (0.4 kW)	●	●	●	
		0.45 MPa (0.75 kW)	○	○	○	
		1 MPa (1.1 kW)	○	○	○	
	TSC**	None	●	●	●	
		2 MPa (1.5kW)	○	○	○	
		2 MPa (4 kW)	○	○	○	
		3 MPa (2.9 kW)	○	○	○	
		7 MPa (7.5 kW)	○	○	○	
	Water soluble Coolant Chiller***		○	○	○	
	TOP FLUSHING		○	○	○	
SHOWER (200 L/min)		○	○	○		
Chip disposal	Chip conveyor	Chip pan	●	●	●	
		Hinged type (Left/Right/Rear)	○	○	○	
		Magnetic scraper type (Left/Right/Rear)	○	○	○	
		Screw(AUGER) type (Left/Right)	○	○	○	
		DRUM type (Right)	○	○	○	
Chip bucket	○	○	○			
Precision machining option	Linear scale	X / Y / Zaxis	○	○	○	
	AICC II (200 block)		●	●	●	
	SSP (Smooth Surface Package)		○	○	○	
Measurement & Automation	Automatic tool measurement	TS27R	○	○	○	
	Automatic tool breakage detection	OTS	○	○	○	
	Automatic workpiece measurement	BK97 (NEEDLE TYPE ON TABLE)	○	○	○	
	Automatic front door with safety device	OMP60_RENISHAW	○	○	○	
Accessories	WORK LIGHT	LED LAMP	●	●	●	
	OPERATOR CALL LAMP	3-COLOR SIGNAL TOWER(LED)	●	●	●	
	LEVELING BLOCK & BOLT	-	●	●	●	
	SMART THERMAL CONTROL	SENSORLESS TYPE(ONLY SPINDLE)	●	●	●	
	ASSEMBLY & OPERATION TOOLS KIT	-	●	●	●	
	4TH AXIS PREPARATION CABLING FOR SERVO/1-PNEUMATIC PIPING	FACTORY READY MADE	○	○	○	
	AIR GUN		○	○	○	
	Air blower		○	○	○	
	Coolant gun		○	○	○	
	Mist collector		○	○	○	
Customized Special Option	ANCHORING (1)		SLIDE CLAMP & CHEMICAL ANCHOR BOLT			
	TSA (2)		○			
	TOOL TYPE		HSK63A			
	ATC		60T			
	Drum chipconveyor (Rear type)		SCRAPER TYPE			
	20 Bar TSC with inverter		50Hz → 60Hz			
	FINE DUST PROTECTING PACKAGE	WET MACHINING	BELLOWS COVER(X/Y/Z)	○	○	○
			PROTECT COVER(X-AXIS)	○	○	○
			BALL SCREW BELLOWS COVER(X/Y)	○	○	○
		DRY MACHINING	GUIDE WAY DOUBLE WIPER	○	○	○
			PROTECT COVER(X-AXIS)	○	○	○
			BALL SCREW BELLOWS COVER(X/Y)	○	○	○
	AUTO TOOL LENGTH MEASUREMNT		LTS			
			RTS			
			NC4			
AUTO TOOL BREAKAGE DETECTION		MSC/BK9(NEEDLE TYPE ON MAGAZINE)				

\* Please contact DN Solutions for detailed specification information. ● Standard ○ Optional X N/A

\* When using a semi-synthetic type or synthetic type, contact our sales representative or service center in advance.

\*\* If this option is selected, the TSA(Through Spindle Air) Max.pressure is 0.54MPa \*\*\* Technical consultation is mandatory for the chilling of non-water soluble coolant

\*\*\*\* Applicable only to FANUC and HEIDENHAIN NC

(1) Please refer to foundation drawing in relation to anchoring. If more detailed information is required consult with DN Solutions service

(2) If TSC is not required - TSA can be selected as an option.

**Fire Safety Precautions** | There is a high risk of fire when using non-water-soluble cutting fluids, processing flammable materials, neglecting the controlled and careful use of coolants and modifying the machine without the consent of the manufacturer. Always check the SAFETY GUIDELINES carefully before using the machine.

# PERIPHERAL EQUIPMENT

## Grease lubrication system

The standard grease lubrication system eliminates the need for an oil skimmer and reduces lubrication costs by about 60% compared to oil lubrication.

### Yearly maintenance cost

Reduced by  
Max. **60%**



## Raised column OPTION

When the distance between the table and the spindle nose needs to be extended, for example, to accommodate a fixture or a rotary table, the solid one-piece raised column can be raised to increase the distance required.

Height  
**150/200/300 mm**  
(5.9/7.9/11.8 inch)

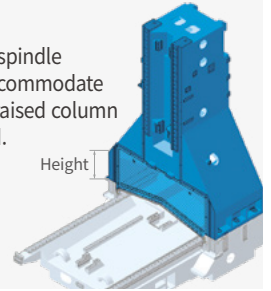

## Chip conveyor OPTION

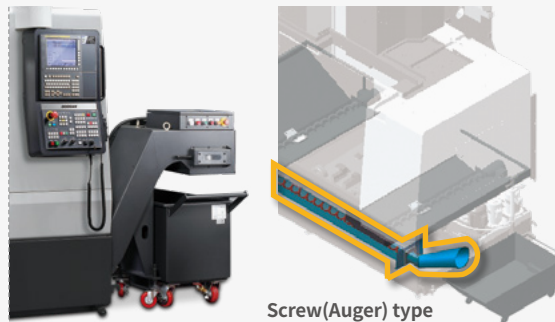
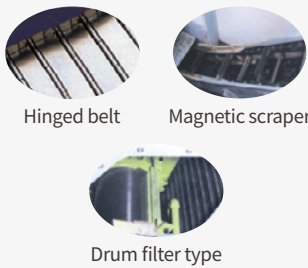

Chip conveyor type	Material	Description
Hinged belt	Steel	Hinged belt chip conveyor, which is most commonly used for steel work [for cleaning chips longer than 30mm (1.2inch)], is available as an option.
Magnetic scraper	Cast Iron	Magnetic scraper type chip conveyor, which is ideal for die-casting work [for cleaning small chips], is available as an option.
Screw(Auger) type	Steel	Screw(Auger) type chip conveyor is suitable for minimizing installation space. About 85% floor space is required to install Screw(Auger) type chip conveyor compared to Hinged belt type.
Drum filter type	Aluminium	Drum filter type chip conveyor, which is ideal for aluminium work [for filtering small chips], is available as an option.

## Programmable flood coolant OPTION

Option to increase tool life and increase user convenience by automatically adjusting the nozzle angle according to the specified tool length and spraying reciprocally.

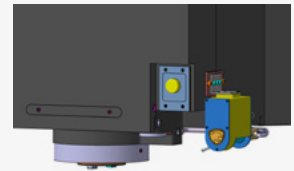

## Chip bucket OPTION

Capacity  
**300 L**  
(79.3 gal)



## Hydraulic / Pneumatic fixture line OPTION

The user should prepare pipelines for hydraulic/pneumatic fixtures whose detailed specifications should be determined through discussions with DN Solutions.

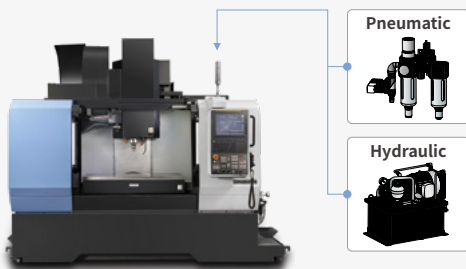

## 4 axis rotary table OPTION

The high-precision split system with its compact and highly rigid design, and double piston structure enables vertical and horizontal use and delivers a strong clamping force.



## OP height adjustment function OPTION

3 Steps at 40mm intervals  
(Upper 2 steps & Lower 1 step)

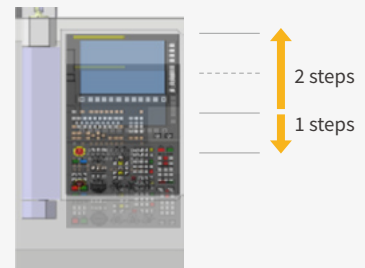

## AWC system OPTION

A compact automatic workpiece change system



Max. workpiece dimensions	Unit	Count	Max. loading	Max. construction height on the pallet	Applicable model
250 x 250 (9.8x9.8) or ø300 (11.8)	mm	12	130 kg (286.6 lb)	350 mm (13.8 inch)	DNM 4500 / 4500L / 5700 / 5700L / 6700 / 6700L
350 x 350 (13.8x13.8) or ø400 (15.7)	mm	8	300 kg (661.4 lb)		DNM 4500 / 4500L / 5700 / 5700L / 6700 / 6700L
400 x 400 (15.7x15.7) or ø450 (17.7)	mm	6			DNM 4500 / 4500L / 5700 / 5700L / 6700 / 6700L
500 x 500 (19.7x19.7) or ø550 (21.7)	mm	4			DNM 5700 / 5700L / 6700 / 6700L

### Pallet Storage-Table Configuration

Unit : mm (inch)

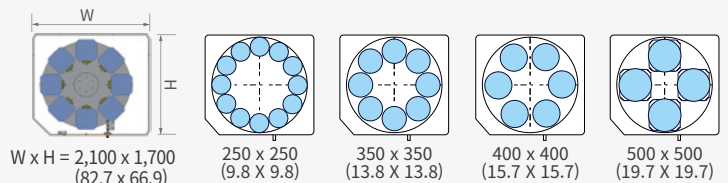

# FANUC i PLUS

Fanuc i Plus is optimized for maximizing customer productivity and convenience.

## 15 inch screen + new operation panel

DN Solutions Fanuc i Plus' operation panel enhances operating convenience by incorporating common-design buttons and layout, and features the Qwerty keyboard for fast and easy operation.

## FANUC i Plus

- 15 inch color display
- Intuitive and user-friendly design

## USB & PCMCIA card QWERTY keyboard

- EZ-guide i standard
- Ergonomic operator panel
- 2MB Memory
- Hot key



## iHMI touchscreen OPTION

iHMI provides an intuitive interface that uses a touchscreen for quick and easy operation.

## Range of applications

Providing various applications related to planning, machining, improvement and utility, for customer convenience.



## NUMERIC CONTROL SPECIFICATIONS

# FANUC

Item		Specifications	DN Solutions Fanuc i (F0i Plus)
Controlled axis	Controlled axes		3 (X,Y,Z)
	Simultaneously controlled axes		4 axes
	Additional controlled Axis	Add 1 Axis (5th Axis)	●
Data input/output	Fast data server		○
	Memory card input/output		●
	USB memory input/output		●
	Large capacity memory(2GB)*2		○
Interface function	Embedded Ethernet		●
	Fast Ethernet		○
	Enhanced Embedded Ethernet function		●
Operation	DNC operation	Included in RS232C interface.	●
	DNC operation with memory card		●
Program input	Workpiece coordinate system	G52 - G59	●
	Addition of workpiece coordinate system	G54.1 P1 X 48 (48 pairs)	●
	Tool number command		T4 digits
	Tilted working plane indexing command	G68.2 TWP	○
Feed function	AI contour control I	G5.1 Q_, 40 Blocks	X
	AI contour control II	G5.1 Q_, 200 Blocks	●
	AI contour control II	G5.1 Q_, 400 Blocks	○
	AI contour control II	G5.1 Q_, 600 Blocks	X
	AI contour control II	G5.1 Q_, 1000 Blocks *1)	X
	High smooth TCP		X
Operation guidance function	EZ Guidei (Conversational Programming Solution)		●
	EZ Operation package		●
Setting and display	CNC screen dual display function		●
Network	FANUC MTConnect		✳
	FANUC OPC UA		✳
Others	Display unit	10.4" color LCD	X
		15" color LCD	X
		15" color LCD with Touch Panel	●
	Part program storage size & Number of registerable programs	640M(256KB)_500 programs	X
		1280M(512KB)_1000 programs	X
		2560M(1MB)_1000 programs	X
		5120M(2MB)_1000 programs	●
		10240M(4MB)_1000 programs	X
		20480M(8MB)_1000 programs	X
		2560M(1MB)_2000 programs	X
		5120M(2MB)_4000 programs	X
		10240M(4MB)_4000 programs	X
		20480M(8MB)_4000 programs	X

\*1) The number of look-ahead blocks may be changed or limited depending on the peripheral device or the configuration of the internal NC system.

# EZ WORK

The software developed by DN Solutions provides a range of different functions designed for fast, efficient and convenient operation.

## EZ work

The EZ work package delivers speed and efficiency. This menu-driven innovation not only helps customers reduce setup times, but also simplifies common tasks and procedures, reducing the potential for errors. EZ work reduces operating time, protects machinery, enhances quality and speeds up maintenance interventions.

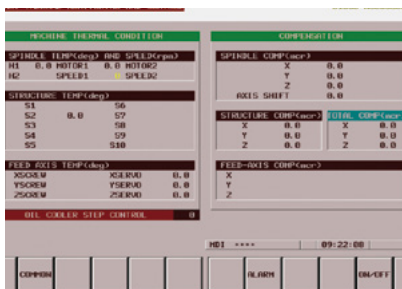

### Sensor type Thermal Compensation (Sensorless type is Standard)

A function to maintain high-precision machining quality by analyzing and correcting the amount of thermal displacement of a structure through a temperature sensor



### M/G-Code List

Functional description of M code and G code



### Tool Management

Function to manage tool information [Tool information / Tool No. / Tool condition (normal, large diameter, worn / damaged, used for the rst time, manual) / Tool name]



### Operation Rate

Machine operation history management function by date based on load

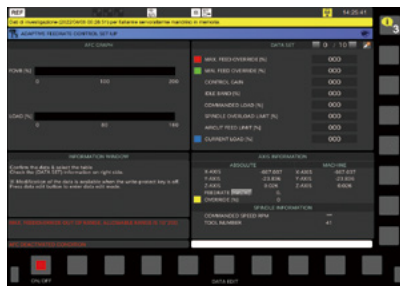

### Adaptive Feed Control

Function to control feedrate so that the cutting can be carried out at a constant load (To adapt to the spindle load set up with constant load feedrate control function)

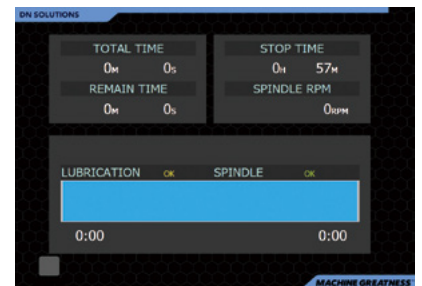

### Spindle Warm Up

A function that assists spindle warm-up for spindle life when the spindle has not been used for a certain period of time



### ATC Recovery

Function to view detailed info with recommended actions and to perform step-by-step operation manually (when an alarm is triggered during an ATC operation)

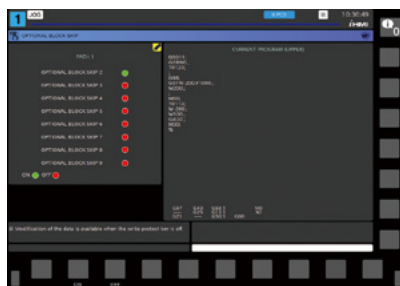

### Addition of Optional Block Skip

In addition to the OPTIONAL BLOCK SKIP of the operation panel, the function to skip a specific block selected in the machining program



### PFC(Programmable Flood Coolant) OPTION

Function to automatically adjust the nozzle angle according to the specified tool length.

# CONVENIENT OPERATION

## HEIDENHAIN TNC620

### Superior hardware specifications

The TNC 620 features optimized motion control, short block processing times and special control strategies. Together with its uniform digital design and its integrated digital drive control (including inverters), it enables you to achieve high machining speeds and the best possible contour accuracy.

- 15.6" display
- 21GB Storage memory
- 1024 look ahead blocks
- High user convenience with folder structure data management



### Conversational convenient function

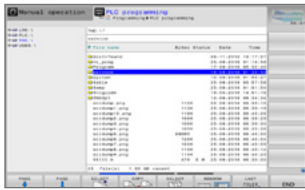

Data are controlled in the folder structure; convenient communication via USB devices



KinematicOpt & KinematicComp **OPTION**  
(Touch probe cycle for automatic measurement)

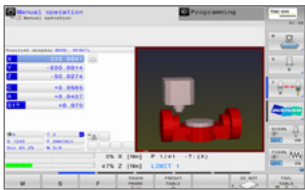

Collision protection system **OPTION**



Adaptive feed control **OPTION**

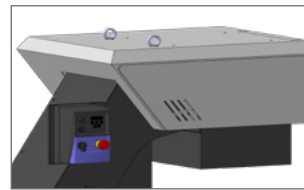

Various built-in pattern cycles for a wider scope of application (Software standard)

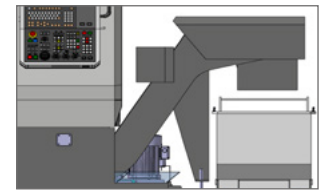

Graphic simulation

## NUMERIC CONTROL SPECIFICATIONS



HEIDENHAIN

Item	Specifications	TNC620
		DNM
Controlled axis	Controlled axis	3 (X,Y,Z)
	Simultaneously controlled axis	4 axis
Data input/output	USB memory input/output	●
Interface function	Embedded ethernet	●
Feed function	Look-ahead 5000 blocks	●
Axis compensation	KinematicsOpt Automatic measurement and optimization of machine kinematics	○
Collision monitoring	Dynamic collision monitoring (DCM)	X
Network	MTConnect	⊕
Others	Display unit 15" color LCD with touch panel	●
	Part program storage size & number of registerable programs 4GB	●

# DN SOLUTIONS M80VA

DN SOLUTIONS M80VA maximizes customer productivity and convenience.

## 15" Touch Screen + New OP

Mitsubishi operation panel enhances operating convenience by incorporating common-design buttons and layout.

It features a Qwerty keyboard for fast and easy data input and operation

## DN SOLUTIONS M80VA

- 15 inch color touch display
- High-speed Simple Program Check
- Ergonomic operator panel
- Hot keys
- 3D Solid program check
- Alarm, Parameter guidance

## USB and SD card QWERTY keyboard

- EZ-Guide standard
- 2.5MB Memory
- Intuitive and user-friendly design



## Front-side USB Memory Mode

The control is able to run a machining program stored in a USB memory when it is inserted into the front USB port of the display unit.

## Front-side SD card mode

The machining program stored in a SD card can be operated. This SD card is installed to the front-side SD card I/F. When a machining program stored in SD card is searched while "Memory Card" is selected for device during operation search, the machining program in SD card can be operated as a main program.



## NUMERIC CONTROL SPECIFICATIONS

MITSUBISHI

Division	Item	Specifications	DNM Series
			M80VA
Controlled axis	Number of Basic Control Axes (NC Axes)	3 ( X,Y,Z )	X,Y,Z
	Number of Simultaneous Contouring Control Axes		4 axes
Input/Output Functions and Devices	Front-side SD Card I/F [Up to 32GB]		●
	Front-side USB Memory I/F [Up to 32GB]		●
	Ethernet I/F		●
	Display Unit-Rearside Data Server I/F		●
Operation	High-speed Simple Program Check		●
Program input	Workpiece Coordinate System Selection (6 Sets)		●
	Extended Workpiece Coordinate System Selection (48 Sets)	G54.1P1 to P48	●
	Tool number command		T2 digits
Feed Function	High-speed Machining Mode I (G05P1) Maximum [kBPM]		● 33.7
	High-speed Machining Mode II (G05P2) Maximum [kBPM]		● 101
	High-accuracy Control (G61.1/G08)		●
	SSS Control		●
	Tolerance Control		●
	High-speed High-accuracy Control I (G05.1Q1) Maximum [kBPM]		● 33.7
	High-speed High-accuracy Control II (G05P10000) Maximum [kBPM]		● 101
	High-speed High-accuracy Control III (G05P20000) Maximum [kBPM]		● 202
	Smooth Fairing		●
Operation Guidance Function	Ethernet Connection		●
	Simple Programming (NAVI MILL/LATHE)		●
	G code Guidance		●
Network	CC-Link Connection		●
Others	Display unit	15" color LCD with Touch Panel	●
	Part program storage size & Number of registerable programs	MEMORY1 : 1280(500KB)_1000 programs	●
		MEMORY2 : 5120M(2000KB)_1000 programs	●

# CONVENIENT OPERATION

## DN SOLUTIONS M80VA

### EZ WORK function

These resources help operators quickly identify issues and take appropriate action without delays. They also standardize workflows which improves overall system stability and reduces training time for new users.



#### EZ-WORK Main Screen

The EZ Work main screen offers a unified and intuitive workspace that lets users monitor status, manage tasks, and access key functions with greater efficiency.



#### Thermal Compensation

A function to maintain high-precision machining quality by analyzing and correcting the amount of thermal displacement of a structure through a temperature sensor.



#### Certification

The Machine Certification screen provides a clear overview of equipment certification status and verification history, supporting reliable operation and systematic quality control.

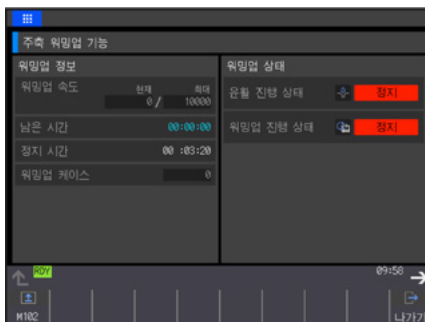

#### Spindle Warm Up

A function that assists spindle warm-up for spindle life when the spindle has not been used for a certain period of time.



#### ATC Recovery

Function to view detailed info with recommended actions and to perform step-by-step operation manually (when an alarm is triggered during ATC operation).

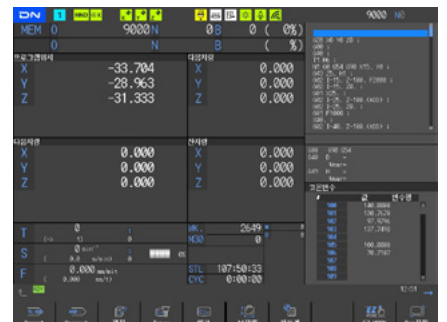

#### NC Screen

The NC Screen has also been fully customized to provide a more intuitive layout, optimized workflows, and enhanced user-specific operation convenience.

### Additional Features

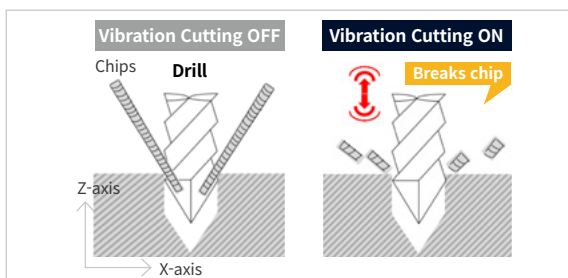

#### CBS (Vibration Cutting Control for Machining Center) OPTION

- The spindle vibrates in the cutting direction to break the chips
- Can be used with the drilling fixed cycle
- Use the function by adding G code commands to existing machining programs (G8.5 P2)

\*H/W Option



No SSS control



With SSS control

#### SSS Control (Super Smooth Surface Control)

- Use the global paths information to control optimum speed
- Reduce the parts which get scratch like marks and streaks on the surface

# CONVENIENT OPERATION

## SIEMENS 828D

### 15.6" screen + new operation panel

The newly-designed operation panel improves the customer convenience by incorporating and using common-design buttons and layouts, and includes the familiar QWERTY keyboard for fast and easy operation.

- 15.6" display
- 10MB high capacity user memory
- USB & ethernet (standard)
- QWERTY keyboard (standard)
- High-speed calculation and simulation can be fulfilled by improved processor functionality



### Conversational convenient function

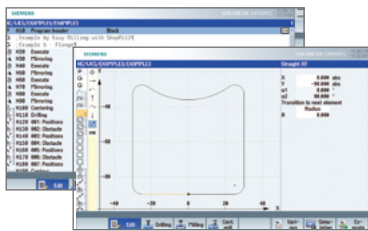

Shop Mill Part Programming

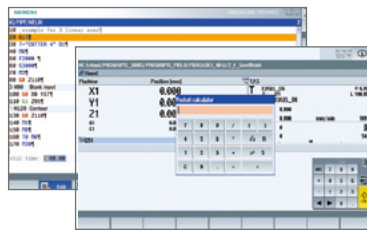

Smart function

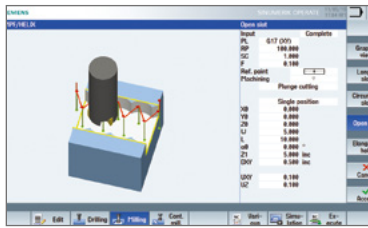

Advanced program language programGUIDE

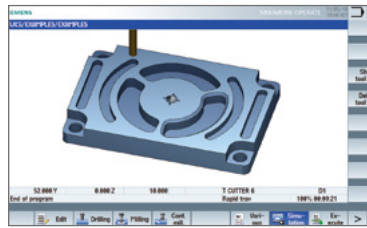

Simulation and machining contour monitoring

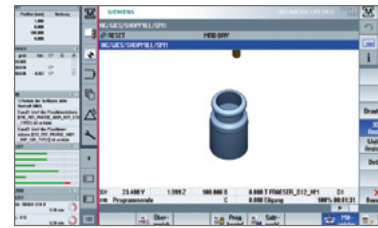

Side screen widget

## NUMERIC CONTROL SPECIFICATIONS



	Item	Specifications	S828D
			DNM
<b>Controlled axis</b>	Controlled axes	-	3 axis
	Simultaneously controlled axes	-	3 axis
<b>Data input/output</b>	Memory card input/output	(Local drive)	X
	USB memory input/output		●
<b>Interface function</b>	Ethernet	(X130)	●
<b>Operation</b>	On network drive	(without EES option, Extcall)	●
	On USB storage medium, e.g. memory stick	(without EES option, Extcall)	●
<b>Program input</b>	Workpiece coordinate system	G54 - G57	●
	Addition of workpiece coordinate system	G505 - G599	●
<b>Interpolation &amp; Feed function</b>	Advanced surface		●
	Top surface		○
	Look ahead number of block	S/W version 4.95	450
<b>Programming &amp; Editing function</b>	3D simulation, finished part		●
	Simultaneous recording		●
	Measure kinematics		X
	DXF Reader for PC integrated in SINUMERIK Operate		○
<b>Operation Guidance Function</b>	ShopMill		●
	EZ Work		●
<b>Setting and display</b>	Operation via a VNC viewer		●
<b>Network</b>	MTConnect		●
	OPCUA		○
<b>Etc. function</b>	15.6" color display with touch screen		●
	19" color display without touch screen		X
	21.5" color display with touch screen		X
	CNC user memory	10 MB	●
	Expansion by increments	2 ~ 12 MB	○
	Collision avoidance		X
Collision avoidance ECO (machine, working area)		X	

# POWER | TORQUE

FANUC

## DNM 4500/L · 5700/L

### 8000 r/min

Max. spindle power : 18.5 kW (24.8 Hp)  
 Max. spindle torque : 117.8 N·m (86.9 lbf-ft)

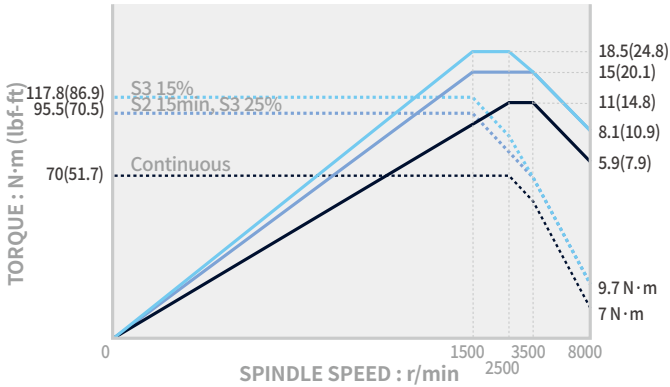

### 8000 r/min OPTION

Max. spindle power : 15 kW (20.1 Hp)  
 Max. spindle torque : 286 N·m (211.1 lbf-ft)

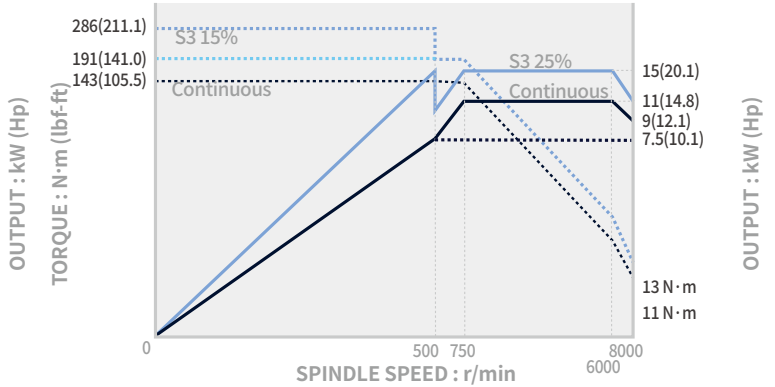

## DNM 6700/L

### 8000 r/min

Max. spindle power : 18.5 kW (24.8 Hp)  
 Max. spindle torque : 117.8 N·m (86.9 lbf-ft)

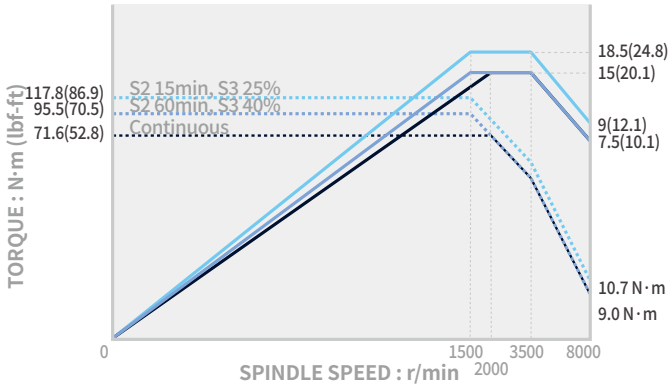

### 8000 r/min OPTION

Max. spindle power : 15 kW (20.1 Hp)  
 Max. spindle torque : 286 N·m (211.1 lbf-ft)

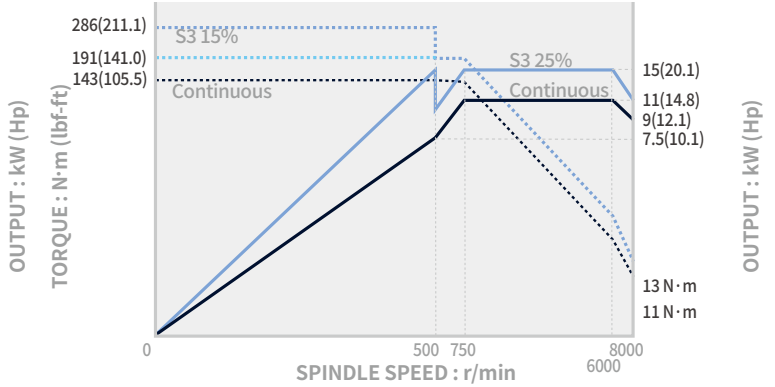

## DNM 4500/L · 5700/L · 6700/L

### 12000 r/min OPTION

Max. spindle power : 18.5 kW (24.8 Hp)  
 Max. spindle torque : 117.8 N·m (86.9 lbf-ft)

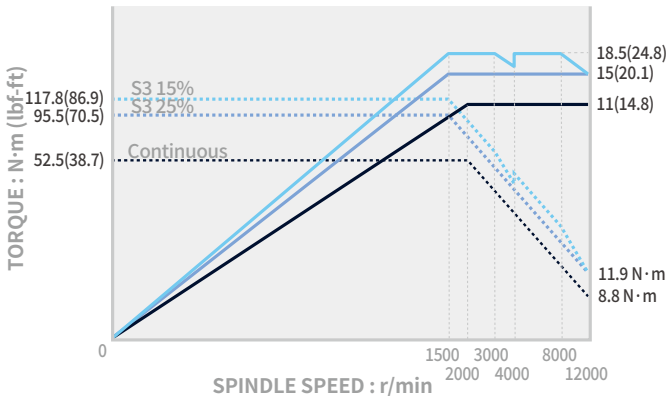

### 15000 r/min OPTION

Max. spindle power : 18.5 kW (24.8 Hp)  
 Max. spindle torque : 117.8 N·m (86.9 lbf-ft)

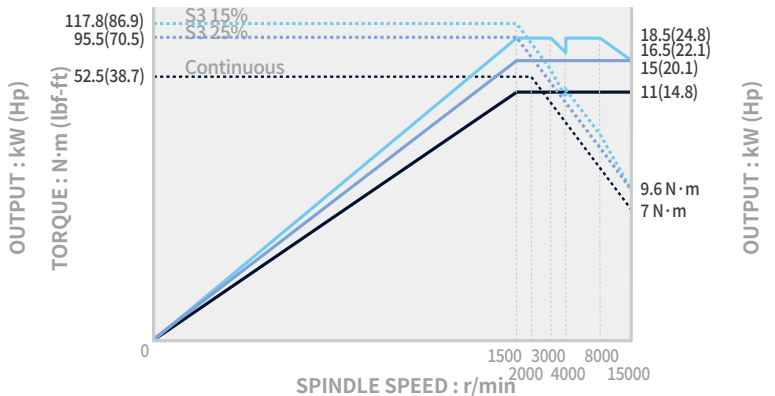

# POWER | TORQUE

SIEMENS | HEIDENHAIN

## SIEMENS\_DNM 4500/L · 5700/L

### 12000 r/min

Max. spindle power : 16.5 kW (22.1 Hp)  
 Max. spindle torque : 141 N·m (104.3 lbf-ft)

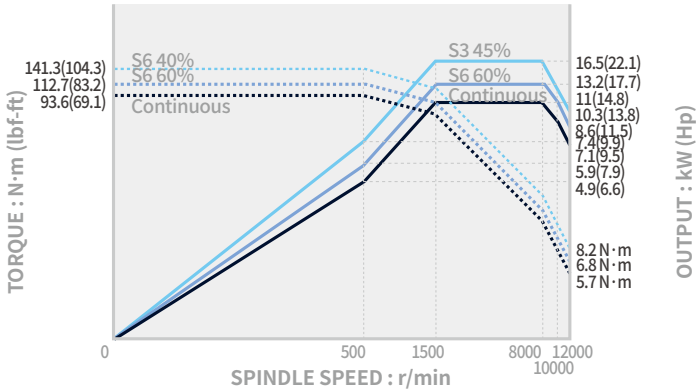

### 15000 r/min

Max. spindle power : 16.5 kW (22.1 Hp)  
 Max. spindle torque : 141.3 N·m (104.3 lbf-ft)

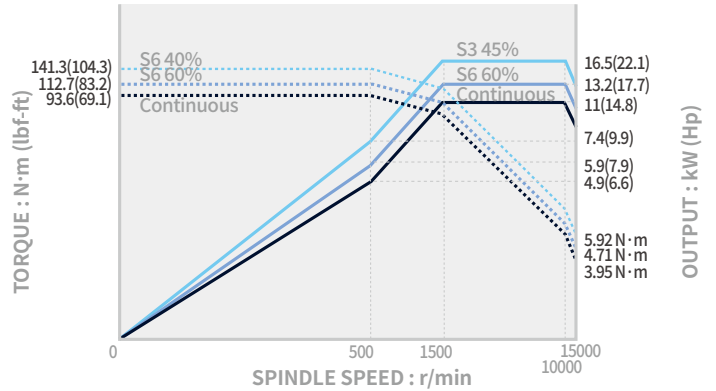

## SIEMENS\_DNM 6700/L

### 12000 r/min

Max. spindle power : 21.8 kW (29.2 Hp)  
 Max. spindle torque : 150.1 N·m (110.8 lbf-ft)

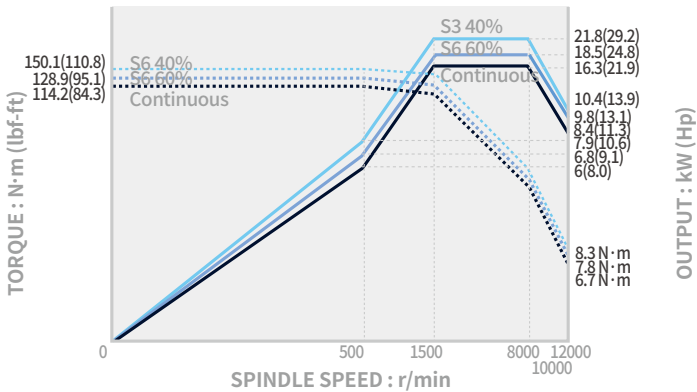

### 15000 r/min

Max. spindle power : 16.5 kW (22.1 Hp)  
 Max. spindle torque : 141.3 N·m (104.3 lbf-ft)

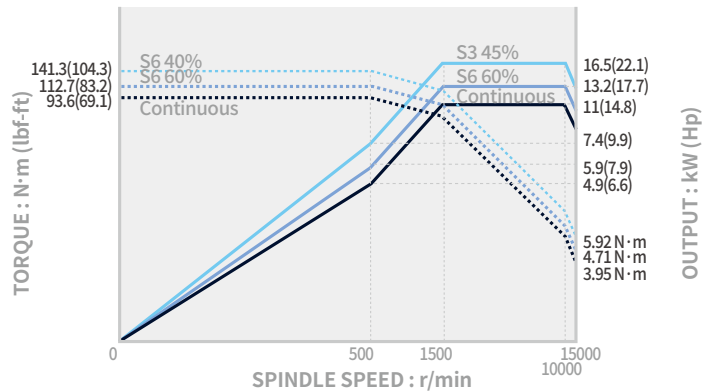

## HEIDENHAIN\_DNM 4500/L · 5700/L

### 12000 r/min

Max. spindle power : 17 kW (22.8 Hp)  
 Max. spindle torque : 108.2 N·m (79.9 lbf-ft)

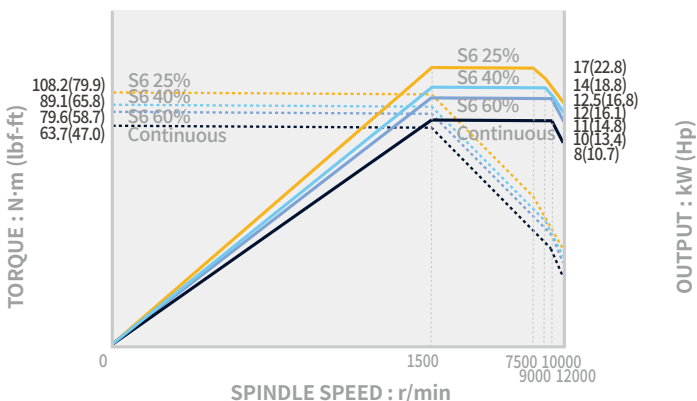

## HEIDENHAIN\_DNM 6700/L

### 15000 r/min OPTION

Max. spindle power : 17 kW (22.8 Hp)  
 Max. spindle torque : 108.2 N·m (79.9 lbf-ft)

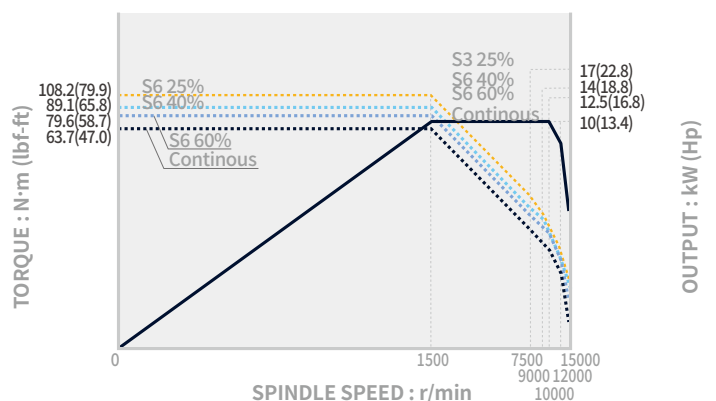

# DIMENSIONS

DNM 4500

TOP

Units : mm (inch)

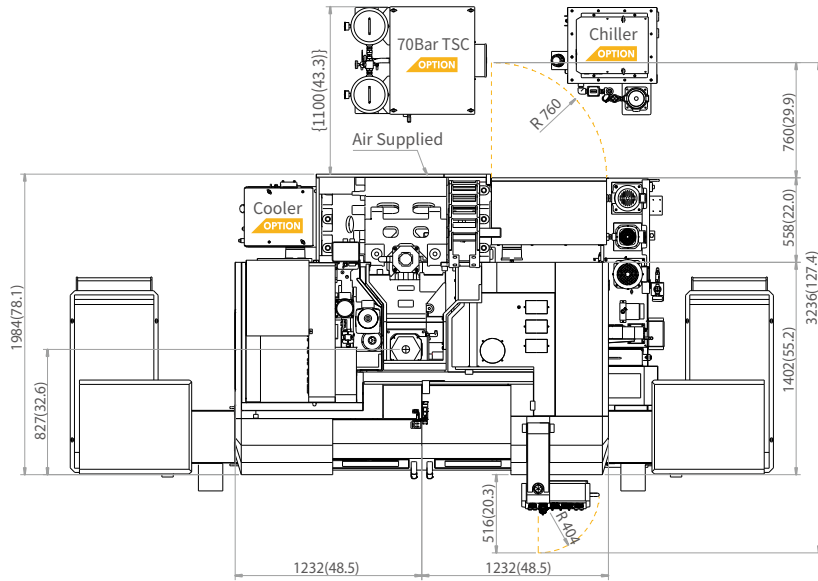

FRONT

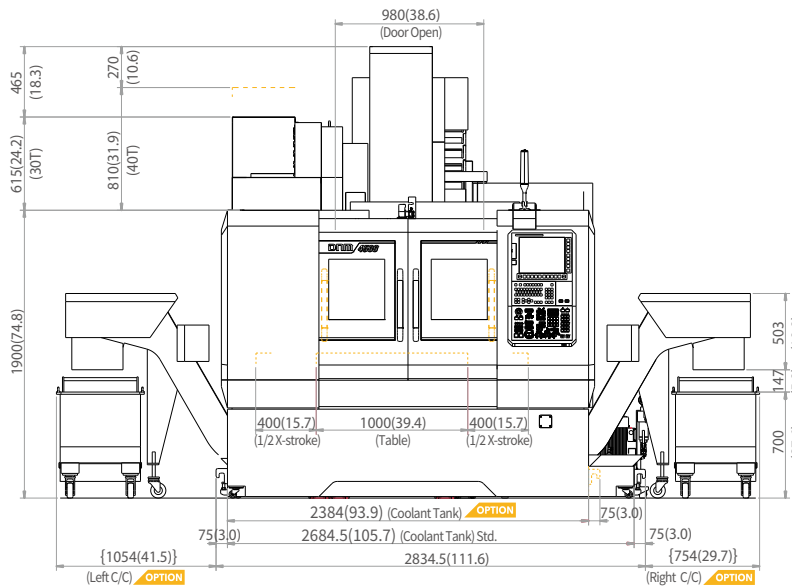

\* If you want a coolant tank that is the same size as your machine, please contact our sales team.

SIDE

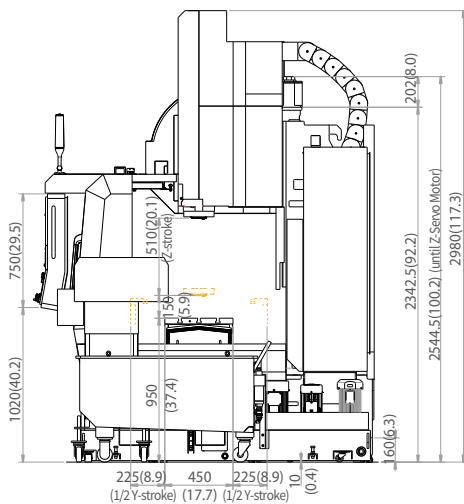

## Table

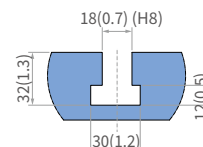
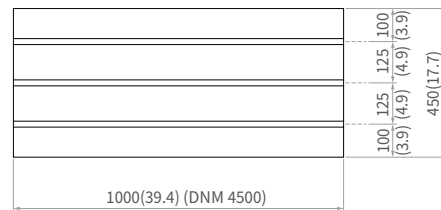

\* Some peripheral equipment can be placed in other places

\*Rear chipconveyor need discuss with sales person

# DIMENSIONS

## DNM 4500L

TOP

Units : mm (inch)

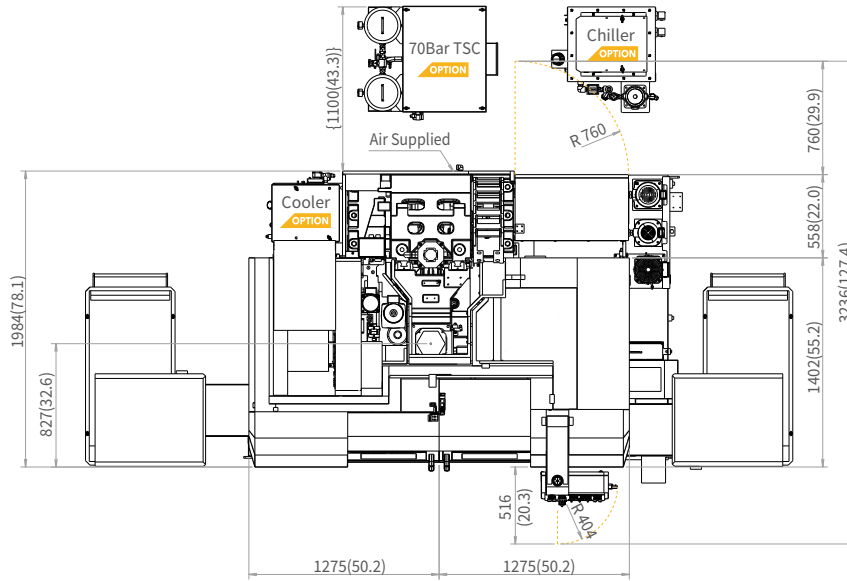

FRONT

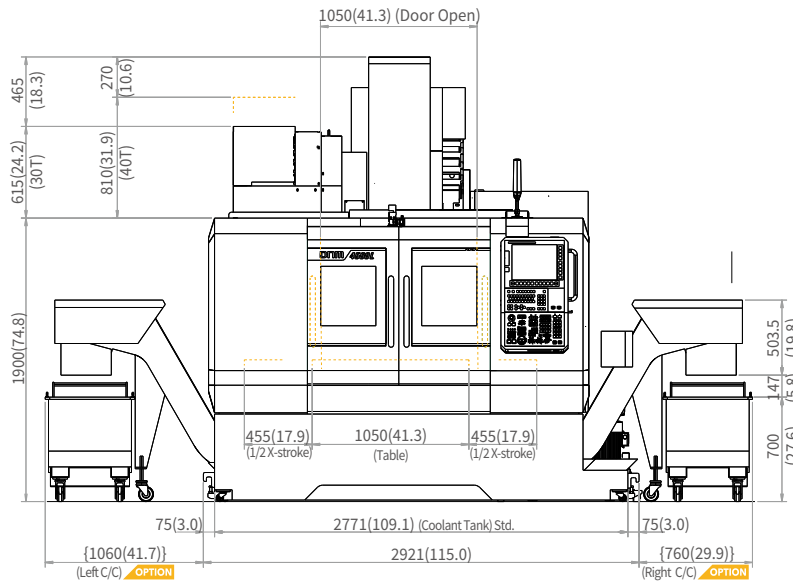

\* If you want a coolant tank that is the same size as your machine, please contact our sales team.

SIDE

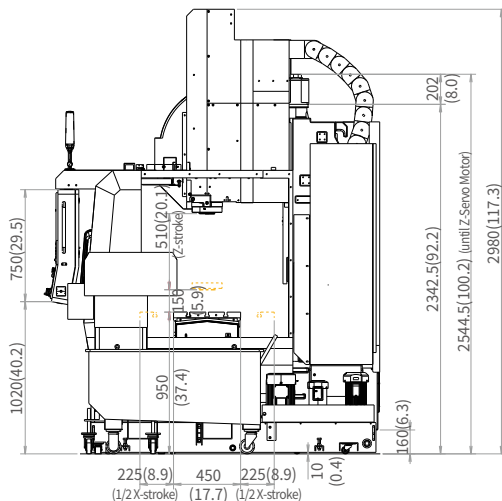

### Table

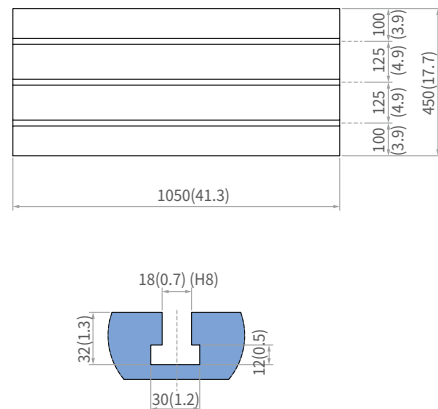

# DIMENSIONS

## DNM 5700

TOP

Units : mm (inch)

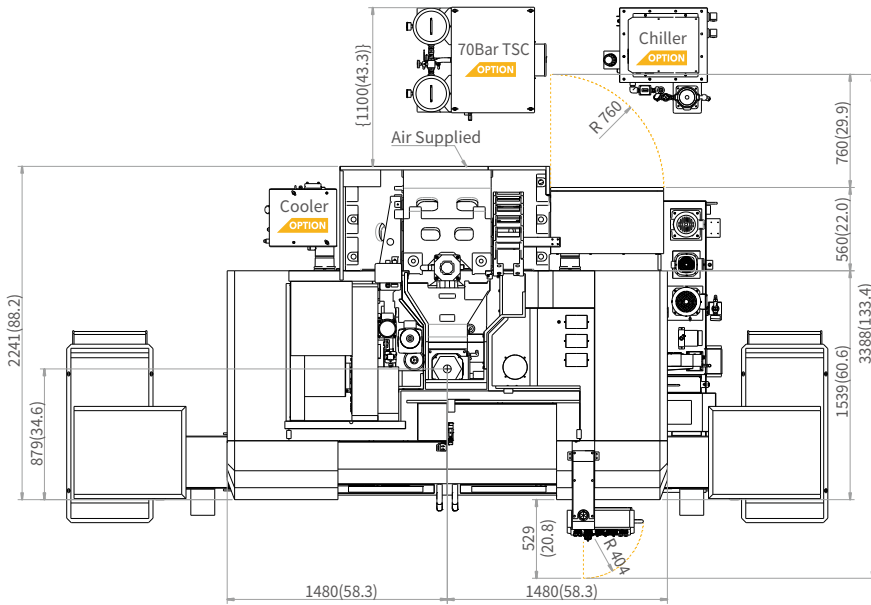

FRONT

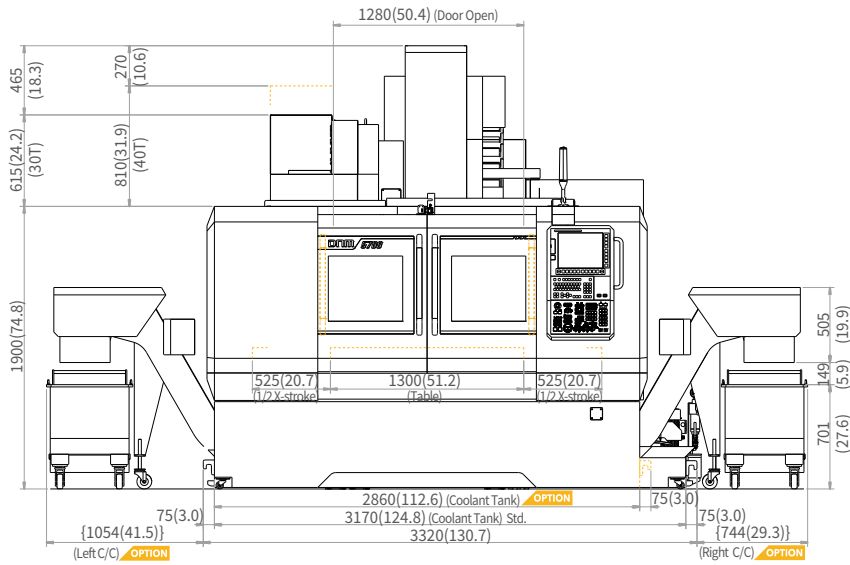

\* If you want a coolant tank that is the same size as your machine, please contact our sales team.

SIDE

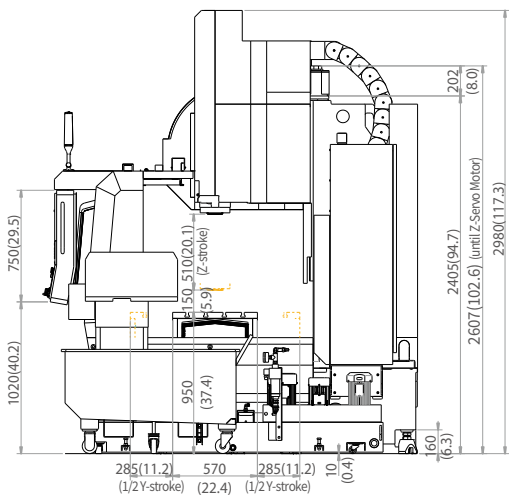

### Table

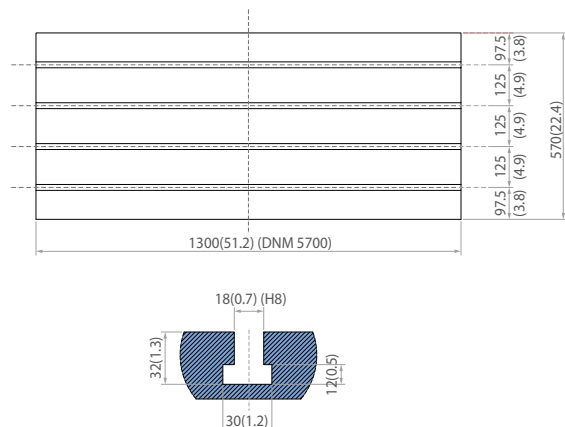

\* Some peripheral equipment can be placed in other places

\* Rear chip conveyor need discuss with sales person

# DIMENSIONS

## DNM 5700L

TOP

Units : mm (inch)

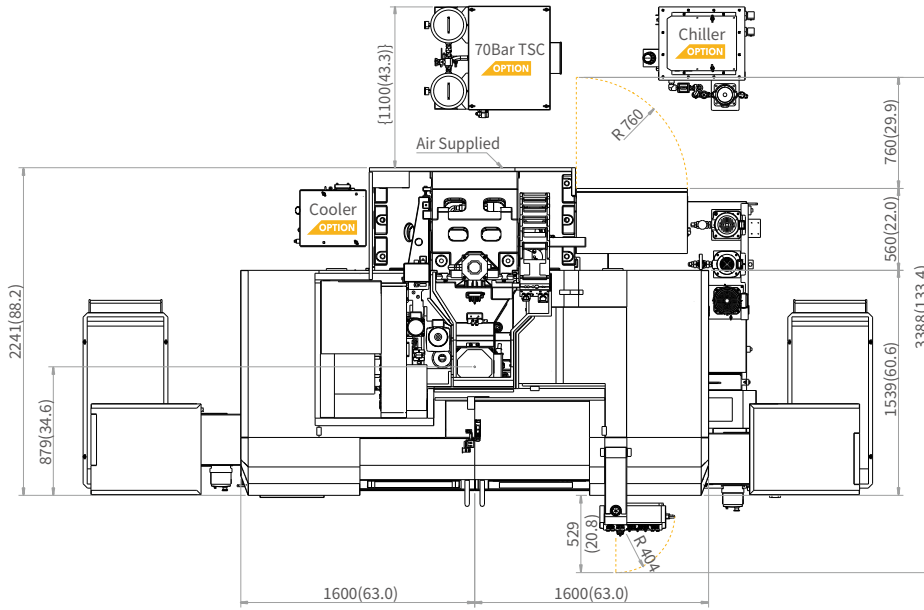

FRONT

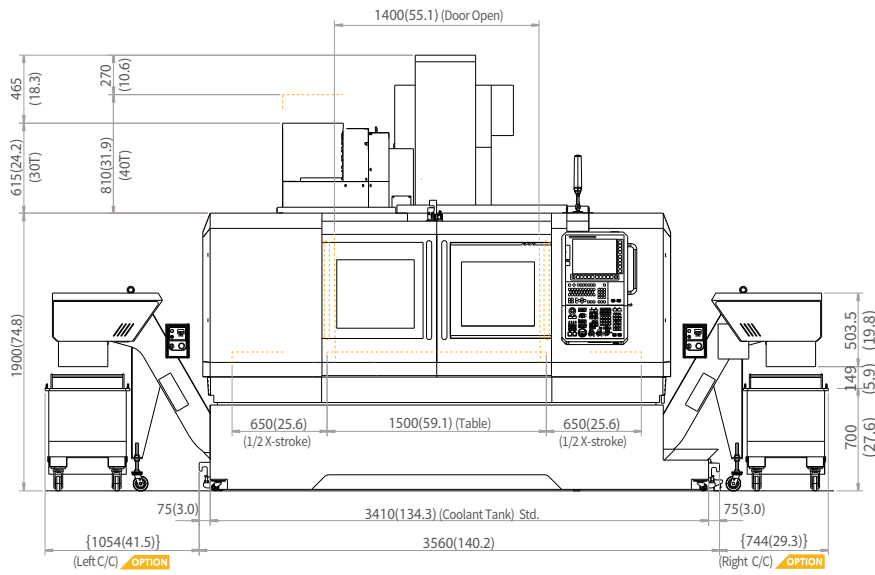

SIDE

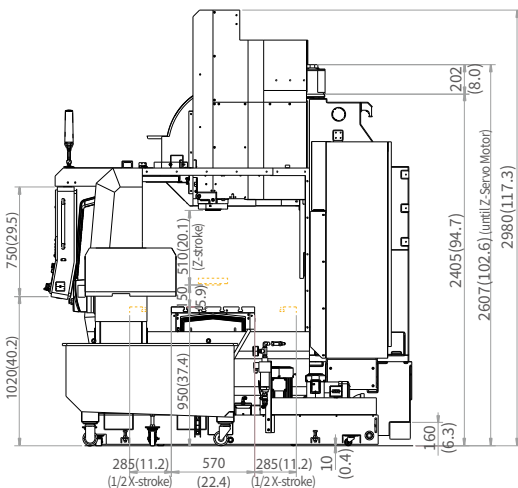

### Table

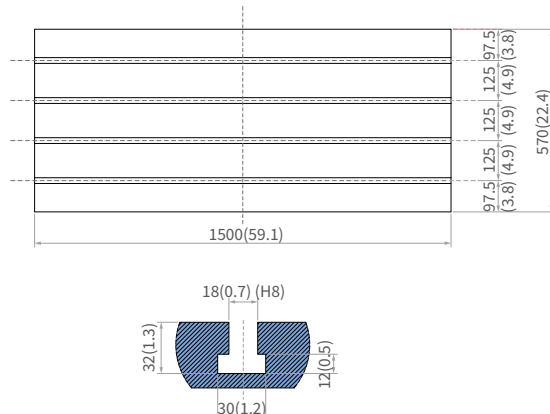

# DIMENSIONS

## DNM 6700

TOP

Units : mm (inch)

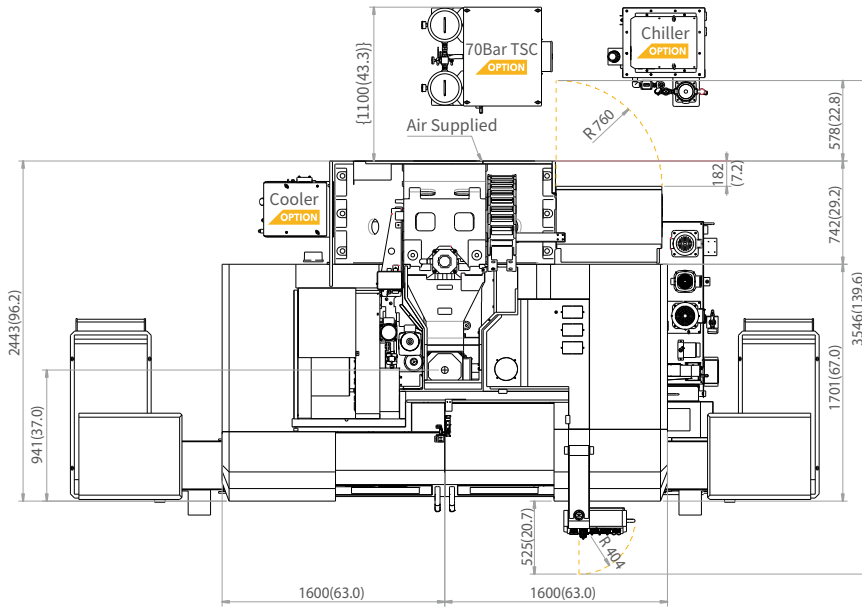

FRONT

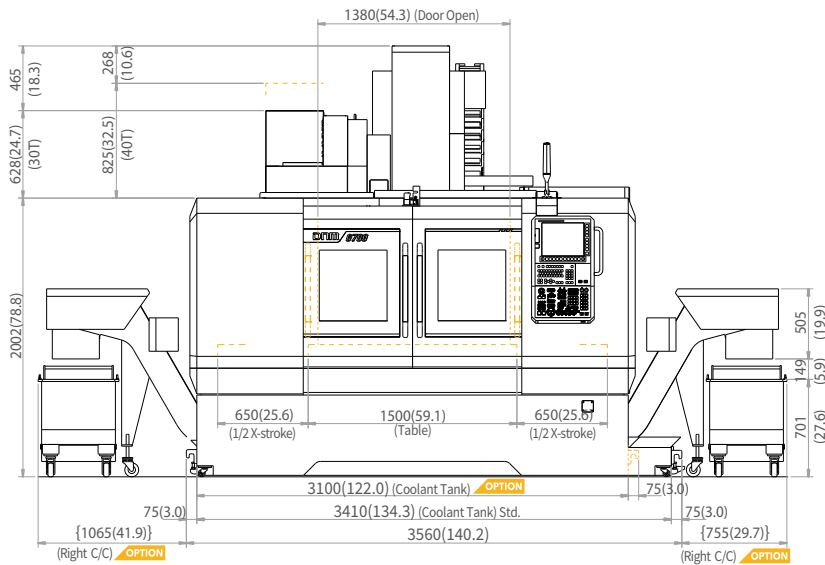

\* If you want a coolant tank that is the same size as your machine, please contact our sales team.

SIDE

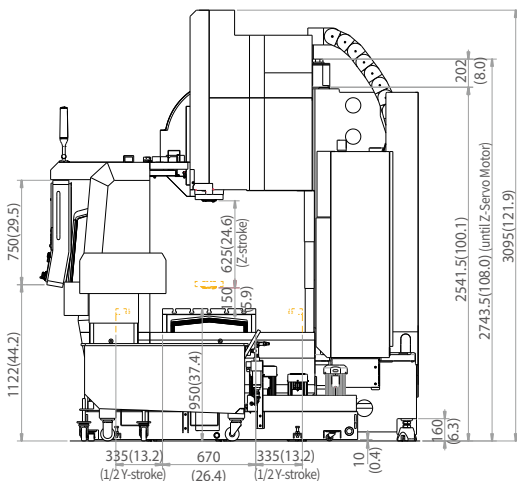

### Table

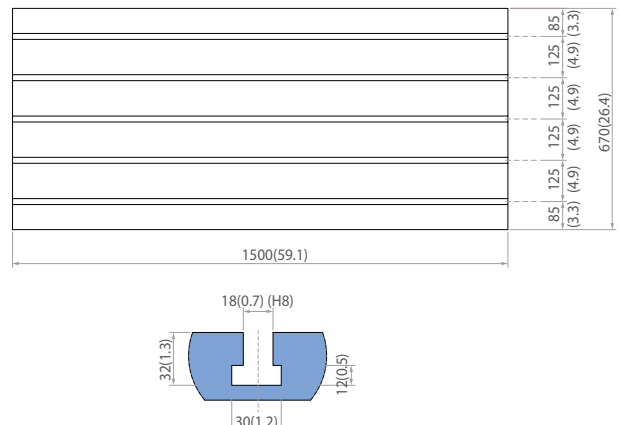

\* Some peripheral equipment can be placed in other places

\*Rear chipconveyor need discuss with sales person

# DIMENSIONS

## DNM 6700L

TOP

Units : mm (inch)

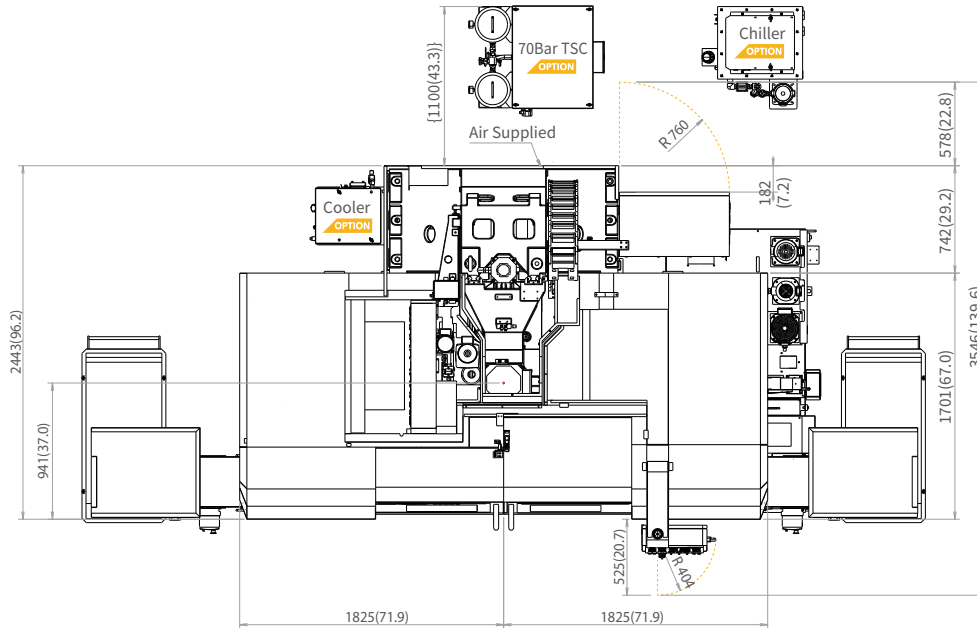

FRONT

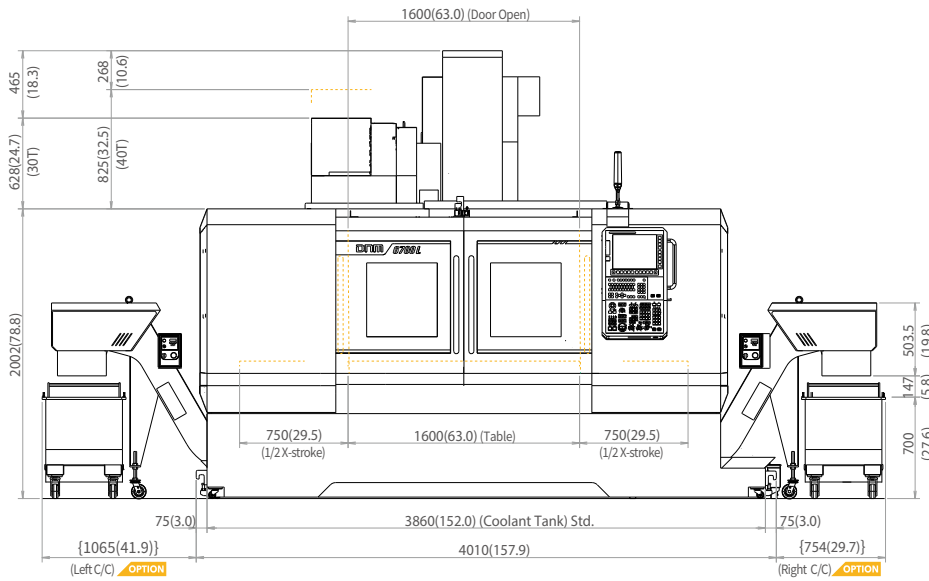

\* If you want a coolant tank that is the same size as your machine, please contact our sales team.

SIDE

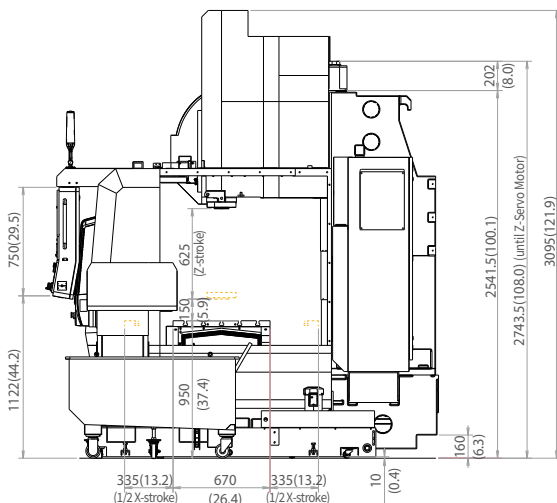

### Table

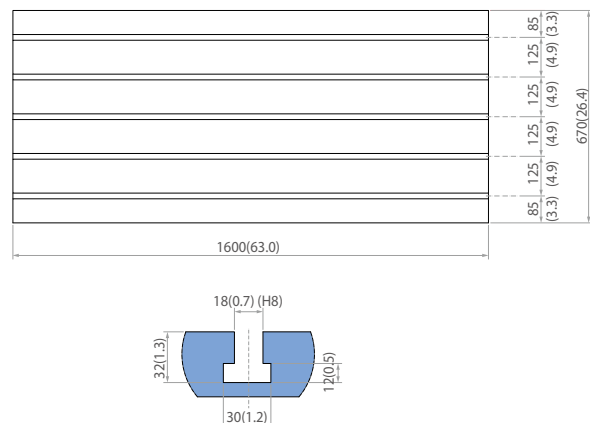

# MACHINE SPECIFICATIONS

Description		Unit	DNM 4500	DNM 4500L	DNM 5700	DNM 5700L	DNM 6700	DNM 6700L	
Travels	Travel distance	X axis	800 (31.5)	910 (35.8)	1050 (41.3)	1300 (51.2)	1300 (51.2)	1500 (59.1)	
		Y axis	450 (17.7)	450 (17.7)	570 (22.4)	570 (22.4)	670 (26.4)	670 (26.4)	
		Z axis	mm (inch)	510 (20.1)			625 (24.6)		
	Distance from spindle nose to table top	mm (inch)	150~660 (5.9~26.0)			150~775 (5.9~30.5)			
Table	Table size	mm (inch)	1000 x 450 (39.4 x 17.7)	1050 X 450 (41.3 x 17.7)	1300 x 570 (51.2 x 22.4)	1500 X 570 (59.1 x 22.4)	1500 x 670 (59.1 x 26.4)	1600 X 670 (63.0 x 26.4)	
	Table loading capacity	kg (lb)	600 (1322.8)	600 (1322.8)	1000 (2204.6)	1000 (2204.6)	1300 (2866.0)	1300 (2866.0)	
	Table surface type	mm (inch)	T-SLOT (3-125(4.9) x 18(0.7)H8)		T-SLOT (4-125(4.9) x 18(0.7)H8)		T-SLOT (5-125(4.9) x 18(0.7)H8)		
Spindle	Max. spindle speed	r/min	8000 {8000*, 12000, 15000}						
	Tool taper	-	ISO #40						
	Max. Spindle power (S3/Cont.)	kW (Hp)	18.5/11 (24.8/14.8) {15/11 (20.1/14.8)*, 18.5/11 (24.8/14.8), 18.5/11 (24.8/14.8)}				18.5/15 (24.8/20.1) {15/11 (20.1/14.8)*, 18.5/11 (24.8/14.8), 18.5/11 (24.8/14.8)}		
	Max. spindle torque	N-m (lbf-ft)	117.8 {286*, 117.8, 117.8}						
Feedrates	Rapid traverse rate	X axis	42 (1653.5)				36 (1417.3)		
		Y axis	42 (1653.5)				36 (1417.3)		
		Z axis	36 (1417.3)				30 (1181.1)		
Automatic Tool Changer	Type of tool shank	Tool shank	BT 40 {CAT 40 / DIN 40}						
		Pull stud	PS806 {Modified DIN / DIN 69872 #40}						
	Tool storage capa.	ea	30{40} / 60 : SQ						
	Max. tool diameter	Continous	80 {76}						
		Without Adjacent Tools	125 (4.9)						
	Max. tool length	mm (inch)	300 (11.8)						
	Max. tool weight	kg (lb)	8 (17.6)						
	Max. tool moment	N-m (ft-lbs)	5.88 (4.3)						
	Tool selection		MEMORY RANDOM						
	Tool change time (Tool-to-tool)	sec	1.2						
Tool change time (Chip-to-chip)	sec	4.1(w/ Shutter) 3.2(w/o Shutter)				4.4(w/ Shutter) 3.5(w/o Shutter)			
Power source	Electric power supply (rated capacity)	kVA	34.31			38.23			
	Compressed air supply	MPa (psi)	0.54 (78.3)						
Tank capacity	Coolant tank capacity	L (gal)	380 (100.4)	385 (101.7)	430 (113.6)	440 (116.2)	435 (114.9)	470 (124.2)	
Machine Dimensions	Height	mm (inch)	2980 (117.3)			3095 (121.9)			
	Length	mm (inch)	2200 (86.6)	2200 (86.6)	2470 (97.2)	2470 (97.2)	2670 (105.1)	2670 (105.1)	
	Width	mm (inch)	2835 (111.6)	2921 (115.0)	3320 (130.7)	3560 (140.2)	3560 (140.2)	4010 (157.9)	
	Weight	kg (lb)	5000 (11023.0)	5500 (12125.2)	6500 (14329.8)	7000 (15432.1)	8500 (18739.0)	9000 (19841.3)	
Control	NC system	-	DN Solutions Fanuc i Plus / SIEMENS S828D / HEIDENHAIN TNC620						

# CUSTOMER SUPPORT AND SERVICES

## WE'RE THERE FOR YOU WHENEVER YOU NEED US.

We help our customers operate at maximum efficiency by providing them with a range of tried, tested and trusted services - from pre-sales consultancy to post-sales support.



### FIELD SERVICES

- On-site service
- Machine installation and testing
- Scheduled preventive maintenance
- Machine repair service



### PARTS SUPPLY

- Supplying a wide range of original DN Solutions spare parts
- Parts repair service



### TRAINING

- Programming, machine setup and operation
- Electrical and mechanical maintenance
- Applications engineering



### TECHNICAL SUPPORT

- Supports machining methods and technology
- Responds to technical queries
- Provides technical consultancy

# RESPONDING TO CUSTOMERS **ANYTIME, ANYWHERE**

## DN SOLUTIONS GLOBAL NETWORK

**66** COUNTRIES | **140** + SALES NETWORKS | **3** FACTORIES | **6** REGIONAL HQS



## CUSTOMER SUPPORT AND SERVICES

### WE'RE THERE FOR YOU WHENEVER YOU NEED US.

We help our customers operate at maximum efficiency by providing them with a range of tried, tested and trusted services - from pre-sales consultancy to post-sales support.



#### FIELD SERVICES

- On-site service
- Machine installation and testing
- Scheduled preventive maintenance
- Machine repair service



#### PARTS SUPPLY

- Supplying a wide range of original DN Solutions spare parts
- Parts repair service



#### TRAINING

- Programming, machine setup and operation
- Electrical and mechanical maintenance
- Applications engineering



#### TECHNICAL SUPPORT

- Supports machining methods and technology
- Responds to technical queries
- Provides technical consultancy

**Head Office**

19F, 10, Tongil-ro, Jung-gu, Seoul,  
Republic of Korea, 04527

Tel: +82-2-6972-0370  
Fax: +82-2-6972-0400

**DN Solutions America**

360 E State PKWY,  
Schaumburg, IL. 60173,  
United states

Tel: +1-315-265-7500

**DN Solutions Europe**

Emdener Strasse 24, D-41540  
Dormagen, Germany

Tel: +49-2133-5067-100  
Fax: +49-2133-5067-111

**DN Solutions India**

No.82, Jakkur Village  
Yelahanka Hobli,  
Bangalore-560064

Tel: +91-80-2205-6900  
E-mail: [india@dncompany.com](mailto:india@dncompany.com)

**DN Solutions China**

Room 101,201,301,  
Building 39 Xinzhuan Highway  
No.258 Songjiang District  
China Shanghai (201612)

Tel: +86 21-5445-1155  
Fax: +86 21-6405-1472

**DN Solutions Vietnam**

M.O.R.E building 2F, 40A-40B Ut  
Tich Street, 04 Ward 04,  
District Tan Binh District,  
Ho Chi Minh City, Vietnam

Tel: +84 28-7304-0163

**DN Solutions Mexico**

Avenida Parque Bicentenario  
#100 Nave M65L3-6,  
Fraccionamiento San Isidro  
Business Park,  
Santa Rosa Jauregui,  
Querétaro, México

E-mail: [efrain.figueroa@dncompany.com](mailto:efrain.figueroa@dncompany.com)

**Sales inquiry**

[sales@dncompany.com](mailto:sales@dncompany.com)