



PREMIUM SIMULTANEOUS 5-AXIS
MACHINING CENTER

DVF

6500 • 6500T • 8000 • 8000T
8000/50 • 8000T/50



DN SOLUTIONS

DVF 6500/8000 SERIES

The DN Solutions DVF series premium 5-axis vertical machining centers are built for high precision machining of complex parts. The optional table turning function provides the additional flexibility required to finish machine parts in one setting.



DN Solutions DVF 5-axis models, with their rigid travelling column design and fully integrated tables, are available in a range of sizes. They are ideal for machining everything from small high-precision medical parts through to large aerospace jet engine components. DVF machines are the ultimate simultaneous 5-axis machining centres.



HIGH SPEED & PRODUCTIVITY

- 12000, 18000 r/min high-speed spindle
- 2-axis rotary/tilt table
 - Turning function (DVF 8000T only)

HIGH PRECISION

- Integrated thermal compensation systems for spindle and structure
- Spindle cooling provided as standard
- Ballscrew shaft cooling system

USER-FRIENDLY MACHINE

- Compact footprint
- Grease lubrication system
- Easy operator access to machine
- Automation

BASIC STRUCTURE

DVF 6500/8000 series

High rigidity and stable structure with direct axis drive.

Table size

DVF 6500	ø650 x 600 mm ø25.6 inch x 23.6 inch
DVF 6500T	ø650 mm ø25.6 inch
DVF 8000, 8000/50	ø800 x 680 mm ø31.5 inch x 26.8 inch
DVF 8000T, 8000T/50	ø800 mm ø31.5 inch

Maximum workpiece weight

DVF 6500	600 kg <i>TANDEM 1000KG</i> 1322.8 lbs
DVF 6500T	500 kg 1102.3 lbs
DVF 8000, 8000/50	1400 kg 3086.4 lbs
DVF 8000T, 8000T/50	700 kg 1543.2 lbs

Maximum workpiece size

DVF 6500 SERIES	ø840 x H500 mm ø33.1 inch x H19.7 inch
DVF 6500 SERIES	ø1000 x 590 mm ø39.4 inch x H23.2 inch

Table turning function

DVF 6500T	1000 r/min <i>DIRECT DRIVE</i>
DVF 8000T	600 r/min <i>DIRECT DRIVE</i>

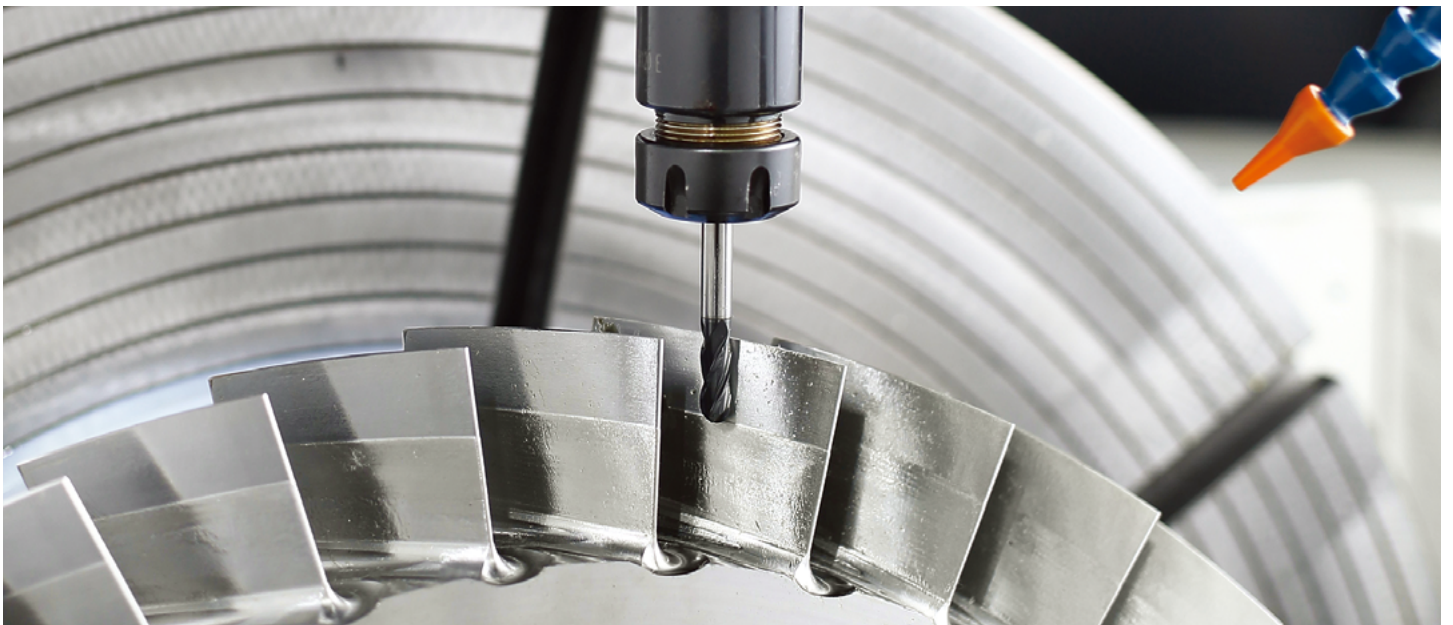

SPINDLE SPECIFICATIONS

DVF 6500/8000 series

Providing stable machining performance with a high-speed, direct-coupled or a built-in spindle.

Speed meets strength with the 5-axis DVF series

An optional 18,000 r/min spindle gives total access to the part while maintaining rigidity, ready for lights-out machining.

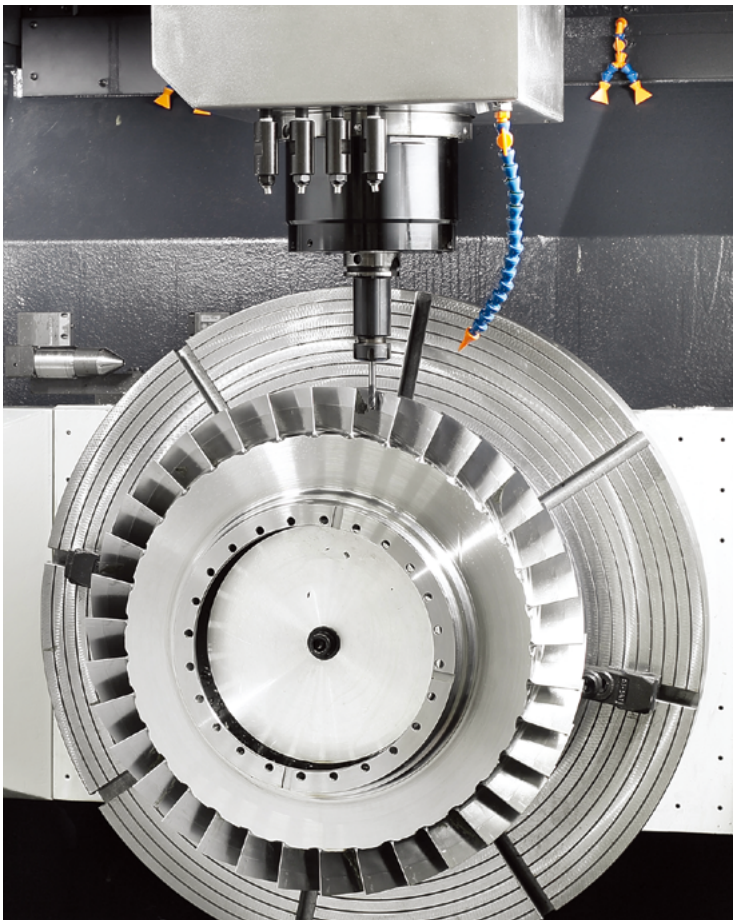

Max. spindle speed

ISO #40 12000 r/min
18000 r/min option

ISO #50 10000 r/min

Max. spindle motor power

ISO #40 FANUC **22 kW** 29.5 hp

SIEMENS
HEIDENHAIN **30 kW** 40.2 hp

ISO #50 FANUC **37 kW** 49.6 hp

Description		DVF 6500 · DVF 8000	DVF 6500T · 8000T	DVF 8000/50, 8000T/50
FANUC	Max. spindle speed	12000 r/min {18000 r/min}	18000 r/min	10000 r/min
	Max. spindle power (S3/continuous)	22 kW/18.5 kW (29.5 hp/24.8 hp)	22 kW/18.5 kW (29.5 hp/24.8 hp)	37 / 25 kW (49.6 hp/33.5 hp)
	Max. spindle torque	229 N · m {221 N · m} (169.0 {163.1} ft-lbs)	117 N · m (86.3 ft-lbs)	488 N · m (360.1 ft-lbs)
HEIDENHAIN SIEMENS	Max. spindle speed	12000 r/min {18000 r/min}	18000 r/min	10000 r/min
	Max. spindle power (S6 40%/continuous)	30 kW/24 kW (40.2 hp/32.2 hp)	30 kW/24 kW (40.2 hp/32.2 hp)	37 / 25 kW (49.6 hp/33.5 hp)
	Max. spindle torque	155 N · m {155 N · m} (114.4 ft-lbs {114.4 ft-lbs})	155 N · m (114.4 ft-lbs)	426 N · m (314.4 ft-lbs)





*{ } : option

TABLE VARIANTS

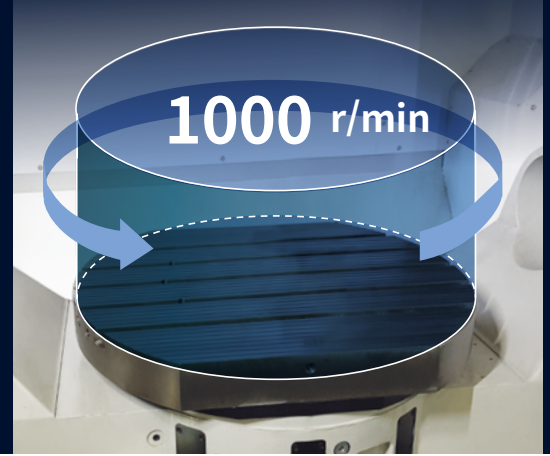
DVF 6500 · 6500T

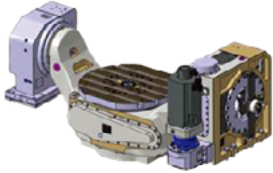
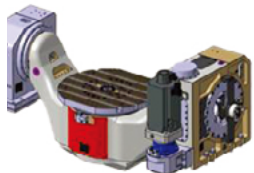
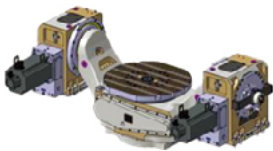
Various table specifications from standard mechanical drive to direct drive and turning function.

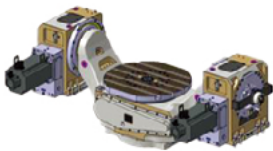

Description	C-axis RGC	C-axis DD
A-axis RGC single Standard	Job Shop <ul style="list-style-type: none"> Highest stiffness High torque 	Die & Mold <ul style="list-style-type: none"> Highest dynamics Continuous operation in C-axis possible Water cooled DirectDrive-technology in C 
	Job Shop (heavy cutting) <ul style="list-style-type: none"> Highest stiffness High torque 	Aerospace (brisk, impeller) <ul style="list-style-type: none"> Highest dynamics Best position uncertainty in A- and C-axis Low-maintenance due to DirectDrive-technology in C 
A-axis RGC tandem		

Swiveling rotary table · single drive

Description	Unit	Roller Gear Cam	Direct Drive
Table size	mm (inch)	ø650 X 600 (ø25.6 X 23.6)	
Maximum load	kg (lb)	600 (1322.8)	
Maximum workpiece size	mm (inch)	ø840 X H500 (ø33.1 X H19.7)	
Torque (rotating axis)	N · m (ft-lbs)	1200 (885.1)	1240 (914.6)
Rapid (rotating axis)	r/min	50 (RGC)*	80 (direct drive)
Torque (tilting axis)	N · m (ft-lbs)	3800 (RGC single)* (2802.7)	
Rapid (tilting axis)	r/min	25	

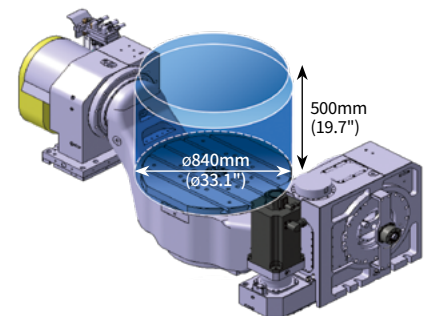

Swiveling rotary table · tandem drive

Description	Unit	Roller Gear Cam	Direct Drive
Table size	mm (inch)	ø650 X 600 (ø25.6 X 23.6)	
Maximum load	kg (lb)	1000 (2204.6)	
Maximum workpiece size	mm (inch)	ø840 X H500 (ø33.1 X H19.7)	
Torque (rotating axis)	N · m (ft-lbs)	1200 (885.1)	1240 (914.6)
Rapid (rotating axis)	r/min	50 (RGC)*	80 (direct drive)
Torque (tilting axis)	N · m (ft-lbs)	4200 (RGC tandem)* (3097.8)	
Rapid (tilting axis)	r/min	25	

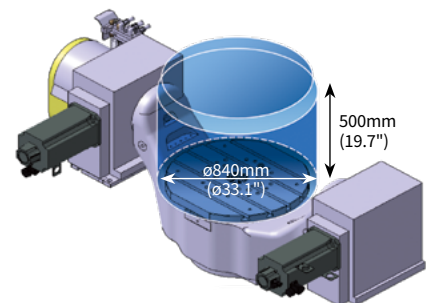

Swiveling rotary table · single/tandem drive for pallet changer

Description	Unit	Roller Gear Cam	Direct Drive
Table size	mm (inch)	ø500 X 500 (ø19.7 X 19.7)	
Maximum load	kg (lb)	600 (with pallet) (1332.8)	
Maximum workpiece size	mm (inch)	ø630 X H430 (ø24.8 X H16.9)	
Torque (rotating axis)	N · m (ft-lbs)	1240 (914.6)	
Rapid (rotating axis)	r/min	80 (direct drive)	
Torque (tilting axis)	N · m (ft-lbs)	3800 (RGC single)* (2802.7)	4200 (RGC tandem)* (3097.8)
Rapid (tilting axis)	r/min	25	

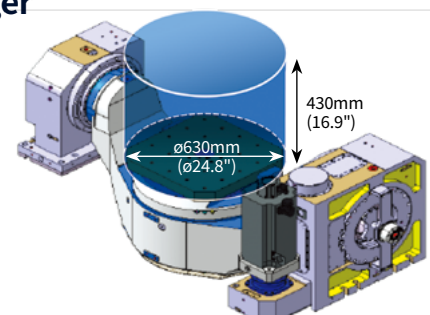

*RGC : Roller Gear Cam

Swiveling rotary table · single/tandem drive for turning

Description	Unit	Specifications
Table size	mm (inch)	ø650 (ø25.6)
Maximum load	kg (lb)	500 (1102.3)
Maximum workpiece size	mm (inch)	ø840 X 590 (ø33.1 X 23.2)
Torque (rotating axis)	N · m (ft-lbs)	1360 (1003.7)
Rapid (rotating axis)	r/min	1000 (with turning)
Torque (tilting axis)	N · m (ft-lbs)	3800 (2804.4) (single) / 4200 (3099.6) (tandem)
Rapid (tilting axis)	r/min	25

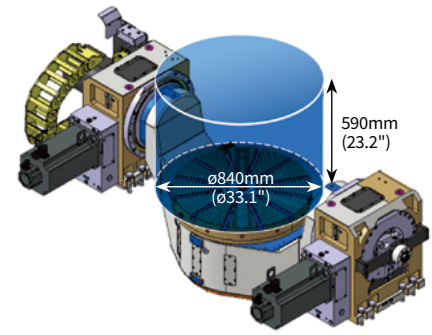
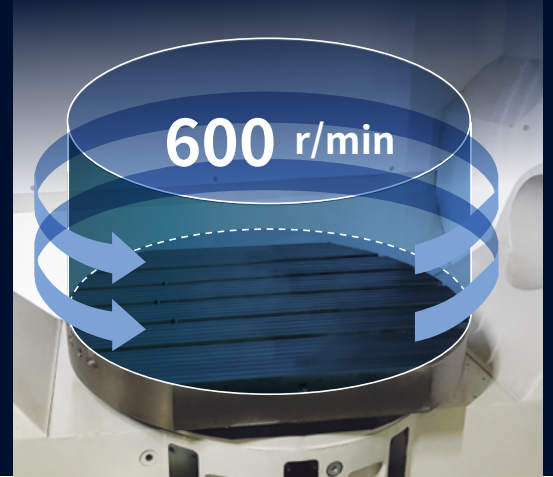

TABLE VARIANTS

DVF 8000 · 8000T · 8000/80 · 8000T/50



Swiveling rotary table · tandem drive

Description	Unit	Specifications
Table size	mm (inch)	ø800 X 680 (ø31.5 X 26.8)
Maximum load	kg (lb)	1400 (3086.5)
Maximum workpiece size	mm (inch)	ø1000 X 590 (ø39.4 X H23.2)
Torque (rotating axis)	N · m (ft-lbs)	2100 (1563.6)
Rapid (rotating axis)	r/min	60 (direct drive)
Torque (tilting axis)	N · m (ft-lbs)	8000 gear train (tandem) (5900.5)
Rapid (tilting axis)	r/min	25

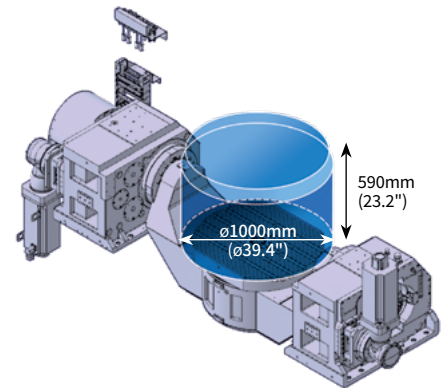

Swiveling rotary table · tandem drive for pallet changer

Description	Unit	Specifications
Table size	mm (inch)	ø630 X 630 (ø24.8 X 24.8)
Maximum load	kg (lb)	850 with pallet (1873.9)
Maximum workpiece size	mm (inch)	ø730 X H490 (ø28.7 X H19.3)
Torque (rotating axis)	N · m (ft-lbs)	2120 (1563.6)
Rapid (rotating axis)	r/min	80 (direct drive)
Torque (tilting axis)	N · m (ft-lbs)	8000 gear train (tandem) (5900.5)
Rapid (tilting axis)	r/min	25

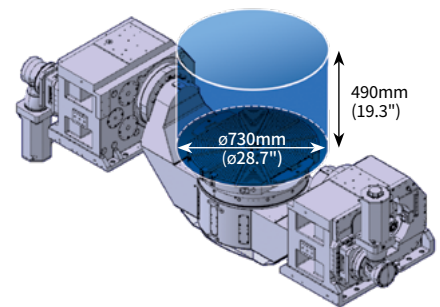

Swiveling rotary table · tandem drive for turning

Description	Unit	Specifications
Table size	mm (inch)	ø650 X 600 (ø25.6 X 23.6)
Maximum load	kg (lb)	700 (1543.2)
Maximum workpiece size	mm (inch)	ø1000 X 590 (ø39.4 X H23.2)
Torque (rotating axis)	N · m (ft-lbs)	2120 (1563.6)
Rapid (rotating axis)	r/min	600 (with turning) (direct drive)
Torque (tilting axis)	N · m (ft-lbs)	8000 gear train (tandem) (5900.5)
Rapid (tilting axis)	r/min	25

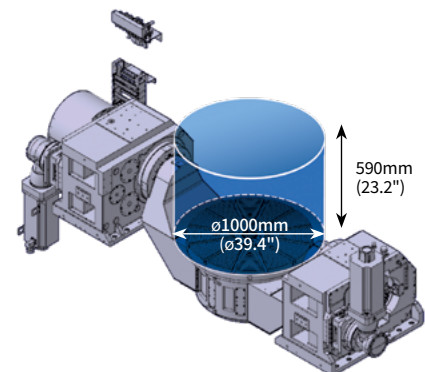

MAGAZINE SPECIFICATIONS

Servo tool magazine delivers high productivity and reliability.

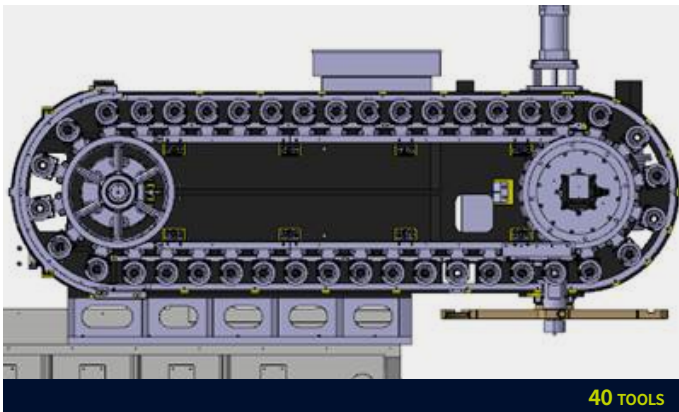

ATC MAGAZINE PANEL

More than 60 tools
(DVF 8000/50: 40 tools)

- Touch panel 7"
(FANUC, HEIDENHAIN)
- Touch panel 8.4"
(SIEMENS)



ISO #40

Tool type

DVF 6500 · 8000

DVF 6500T · 8000T

ISO #40
HSK-T63

Tool capacity

40, 60, 120

Maximum tool diameter

CONTINUOUS **70** mm 3.0 inch

W/O ADJACENT **125** mm 4.9 inch

Maximum tool length

300 mm 11.8 inch

Maximum tool weight

8 kg 17.6 lbs

Tool-to-tool

1.3 second

ISO #50

Tool type

DVF 8000/50

DVF 6500T · 8000T

ISO #50
HSK-T100

Tool capacity

40, 60

Maximum tool diameter

CONTINUOUS **125** mm 4.9 inch

W/O ADJACENT **220** mm 8.7 inch

Maximum tool length

320 mm 12.6 inch

Maximum tool weight

15 kg 33.1 lbs

Tool-to-tool

2.5 second

STANDARD | OPTIONAL SPECIFICATIONS

A range of options is available to suit individual requirements.

Description	Features	DVF 6500	DVF 8000	DVF 6500T	DVF 8000T	DVF 8000/50	DVF 8000T/50
Spindle	12000 r/min	●	●	X	X	X	X
	18000 r/min	○	○	●	●	X	X
	10000 r/min	X	X	X	X	●	●
Magazine	Tool storage capacity	40 ea	●	●	X	X	●
		60 ea	○	○	●	●	○
		120 ea	○	○	○	○	X
Tool shank type	BIG-PLUS® BT40		●	●	X	X	X
	BIG-PLUS® BT50		X	X	X	X	●
	CAT40/DIN/HSK A63		○	○	X	X	X
	CAT50/DIN/HSK A100		X	X	X	X	○
	HSK T63		X	X	●	●	X
	HSK-T100		X	X	X	X	X
Coolant	Flood	2.5 kW 0.44 MPA 100 l/min	●	●	●	●	●
		4.0 kW 2.0 MPA cyclon filter	○	○	○	○	○
	TSC	3.0 kW 3.0 MPA cyclon filter	○	○	○	○	○
		7.5 kW 7.0 MPA cyclon filter	○	○	○	○	○
	Oil skimmer	Belt type	○	○	○	○	○
	Coolant level switch - low/high		○	○	○	○	○
Chip disposal	Chip conveyor	Chip pan	●	●	●	●	●
		Hinged bet, rear side	○	○	○	○	X
		Scraper drum	○	○	X	X	X
		CCS II(Screw-drum/scraper)	○	X	X	X	X
		CCS II(Scraper-drum)	○	○	X	X	○
		CCS II(Hinged-drum)	X	X	○	○	X
	Chip bucket		○	○	○	○	○
	Air gun		○	○	○	○	○
Coolant gun		○	○	○	○	○	
Precision machining option	Linear scale	X/Y/Z-axis	○	○	○	○	●
Measurement & automation	IKC-ready	S/W only	●	●	●	●	●
		Renishaw (RMI-Q) + S/W	○	○	○	○	○
		Heidenhain (SE660) + S/W	○	○	○	○	○
		Blum (RC66) + S/W	○	○	○	○	○
	Datum ball for IKC	None	●	●	●	●	●
		Datum ball D25	○	○	○	○	○
	Touch probe for IKC	None	●	●	●	●	●
		RMP60 Renishaw	○	○	○	○	○
		TS460 Heidenhain	○	○	○	○	○
		TC60 Blum	○	○	○	○	○
	Automatic tool measurement	None	○	○	○	○	○
		RTS Renishaw	○	○	X	X	○
		NC4 Renishaw	○	○	X	X	○
		NC4S Renishaw	○	○	X	X	○
		TT460 Heidenhain	○	○	X	X	○
		ZX Speed Blum	○	○	X	X	○
		BLUM Hybrid	X	X	●	●	●
	NC4 Hybrid Renishaw	X	X	○	○	X	
	Master tool	None	●	●	X	X	●
		Master tool	○	○	●	●	○
Others	LED work light		●	●	●	●	●
	3-color signal tower		○	○	○	○	○
	Tool load monitoring		●	●	●	●	●
	EZ Guide i		○	○	○	○	○
	Automatic power off		●	●	●	●	●
Customized special option	Auto door (w/safety edge)		○	○	○	○	○
	APC		○	○	○	○	○
	APC 3-station/4-pallet)		○	○	○	○	○
	APC + LPS		○	○	○	○	○
	Rotary joint for table		○	○	○	○	○
	Rotary joint for table (APC)		○	○	○	○	○
Paper filter with TSC		○	○	○	○	○	

Please contact DN Solutions for more information.

● Standard ○ Optional X Not applicable

 **Fire Safety Precautions** | There is a high risk of fire when using non-water-soluble cutting fluids, processing flammable materials, neglecting the controlled and careful use of coolants and modifying the machine without the consent of the manufacturer. Always check the SAFETY GUIDELINES carefully before using the machine.

PERIPHERAL EQUIPMENT

Touch type

RENISHAW

TS27R

HEIDENHAIN

TT160

BLUM

ZX SPEED

Laser type

RENISHAW

NC4

NC4S

BLUM

MICRO COMPACT NT

MICRO SINGLE NT

Automatic tool measurement

When using Tool Length Measurement, contact DN Solutions for detailed capacity diagrams

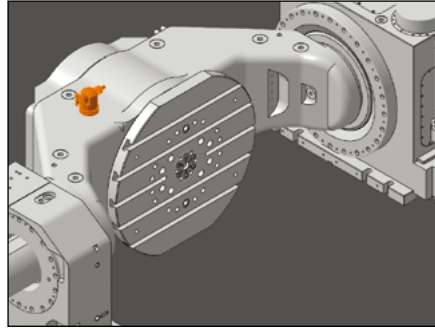

Rotary body mounting type

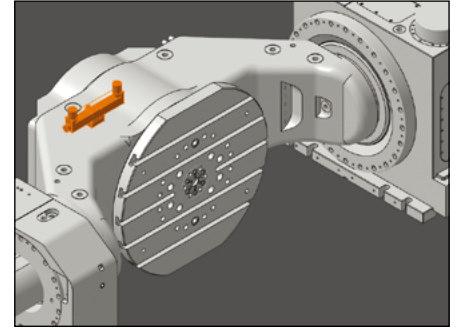

Rotary body mounting type
Renishaw NC4 · Blum MICRO COMPACT NT

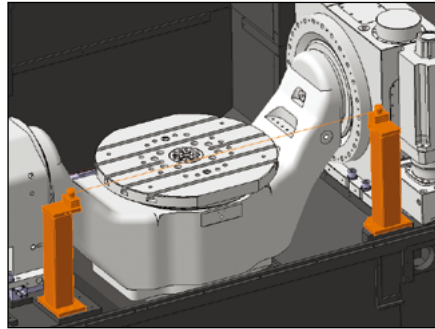

Head separated type
Renishaw NC4S · Blum MICRO SINGLE NT

Intelligent kinematic compensation for 5-axis machining

For high-accuracy 5-axis machining, the Intelligent Kinematic Compensation function is recommended. This function minimizes errors in complex 5-axis machining applications by maintaining the tool point in the correct position relative to the workpiece.

In order to use this function, the following optional items are required:

SOFTWARE

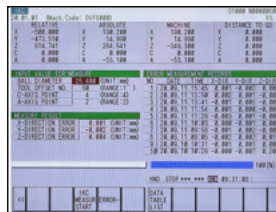

FANUC NC : IKC

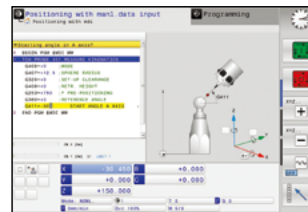

HEIDENHAIN NC ; IKC

RECEIVER Recommended Option



TOUCH PROBE



DATUM BALL Recommended Option



AUTO TOOL MEASUREMENT Recommended Option



MASTER TOOL Recommended Option



AUTOMATION

APC, LPS & Multi-level RPS

No matter which automation option you pair with your DVF 5-axis machine, the combination will help you make parts while you sleep. Learn More about the APC, RPS and LPS below.

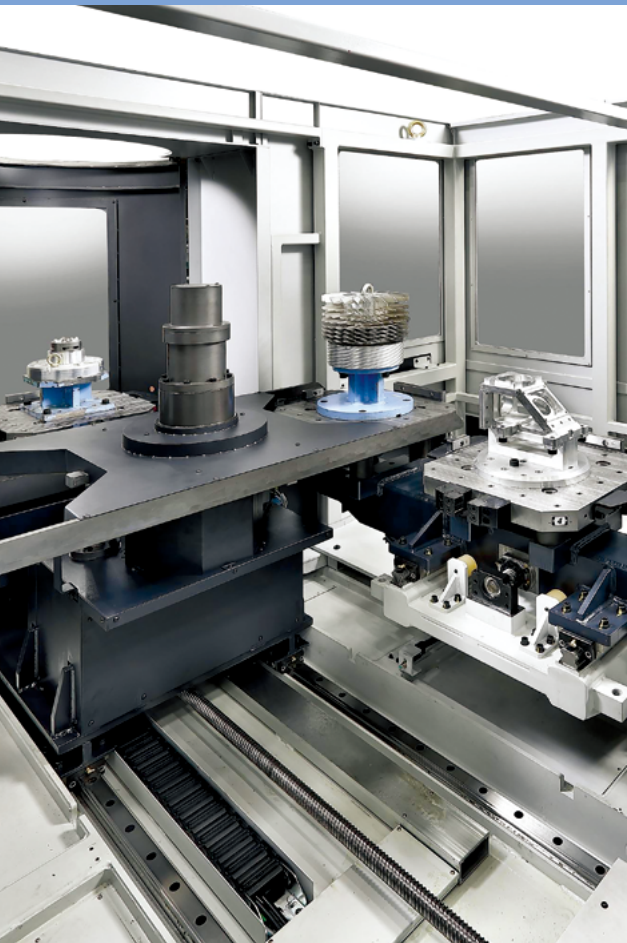

Automatic pallet changer (4APC) :
Adds three pallets to your DVF.

Round pallet system (RPS) :
Seven pallets on three levels for a total of 21 pallets. Includes cell controller.

Linear pallet system (LPS) :
1cell(DVF 6500 with APC + LPS 12pallet), can be expanded by adding more pallets, plus loading stations and more machine interfaces. Includes cell controller.

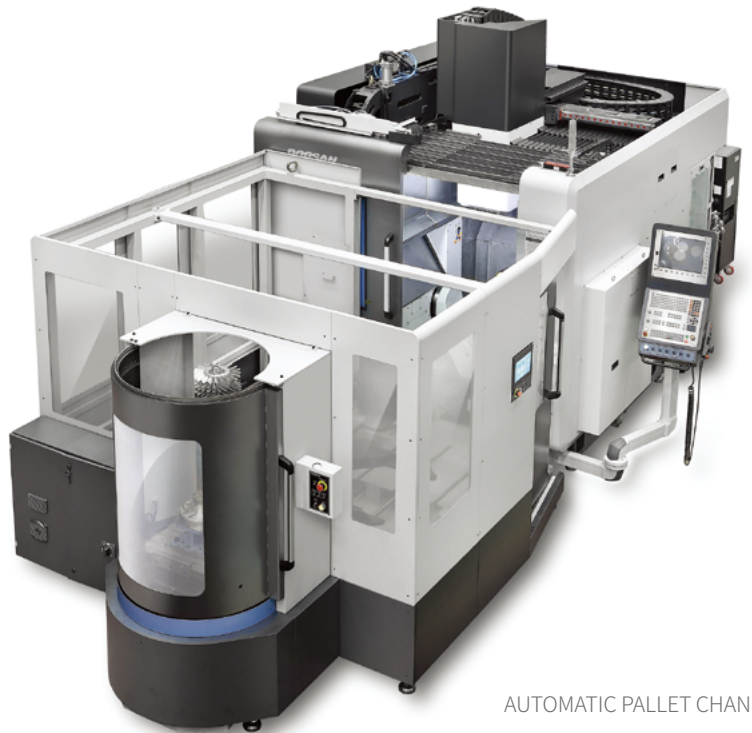

AUTOMATIC PALLET CHANGER



ROUND PALLET SYSTEM



LINEAR PALLET SYSTEM

CUSTOMIZED USER-FRIENDLY FLEXIBLE OPERATION SOLUTIONS

CUFOS is a PC based control system created by DN Solutions. Equipped with intuitive user-friendly functions such as a smart phone screen and easy customization, CUFOS helps to improve operational efficiency and performance for the user.

CUFOS FEATURES

19 INCH TOUCH SCREEN

- Program memory : 2GB (40GB **option**)
- App-based Interface like smart phone, tablet PC

EASY PROGRAMMING

- Conversational Programming
- SSD Data Server : Program file sharing/ managing (CF card/USB/External PC)

EASY SET-UP/OPERATION

- CPS(Collision Protection System)
- Manual Viewer
- File Manager

EASY MAINTENANCE

- Status Monitor
- Alarm Guidance
- Maintenance Manager
- Easy connection with external S/W (creating additional App.)



CUFOS

CUFOS INTERFACE

User-friendly screen controls

CUFOS, the PC-based control created by DN Solutions, is an integrated system solution using an intuitive 19-inch touchscreen. The system provides a convenient operator interface, a high level of customization and many useful high technology apps.



Intuitive operation via touch screen

Simple customization is available for specific work environments.



Supports various apps in three fields—setup, machining and utility

It provides easy configuration by allowing users to add and edit functions on the home screen according to job requirements.

CUFOS open CNC

CUFOS operation for enhanced productivity

The newly-designed operation panel enhances operating convenience by incorporating common-design buttons and layouts, and features the QWERTY keyboard for fast and easy operation.



CUFOS

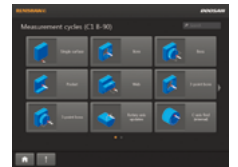

PC software

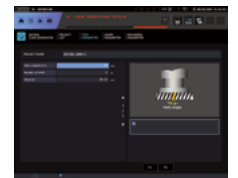

Applications

CUFOS INTERFACE: UTILITIES

Support user convenience functions and additional software modules handling various peripheral devices like measurement.

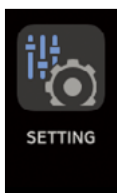

Setting

CUFOS provides management and setting functions such as HMI parameter, user setting, setup manager or e-mail. User setting allows users to register and delete up to six users from the account. CUFOS apps and NC functions can be user-restricted as necessary.

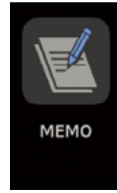

Memo

Users can generate memos, either with a high level of detail via screen capture, or entered by keyboard/touchscreen. The user can add data to existing memos if required. A maximum of 120 memos can be saved



Register up to six user accounts



Screen captures

Memo through touch screen or key board or using a captured screen.

EASY SET-UP & OPERATION

Tool management, Collision Protection between machine unit/ workpiece/tooling and various user guidance provide higher productivity and user-convenience.



Tool management

DN Solutions EOP
(Easy Operation Package)
tool management

Applicable models:
PUMA SMX series/NHP series



Includes a summary monitoring screen and gives the operator easy access to DN Solutions's own tool management system which provides comprehensive real time data on each tool, such as remaining tool life and status of tool groups.



CPS (Collision Protection System)

A function to prevent real-time collision in manual mode between the tool and equipment / machine elements inside the working area.

Use the Setup Manager with the CPS app to build up the machine model, and add tool, workpiece and workholding equipment details.

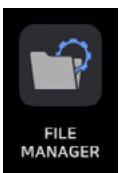
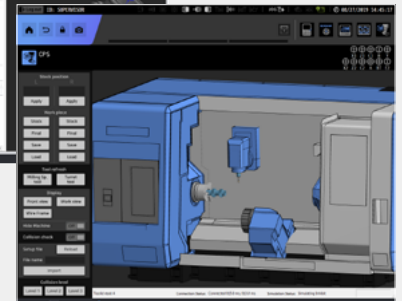
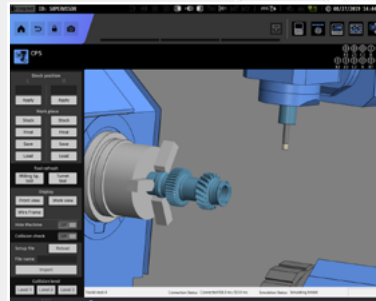

File Manager

Ability to transfer various type of files including CF cards, USB memory, external PCs and memory inside CUFOS, NC programs between NC memory



EASY MAINTENANCE

Keeping a machine in best condition through Status Monitoring, Alarm Guidance and Maintenance manager functions.

CUFOS : STANDARD | OPTIONAL SPECS



Status Monitoring

Monitoring various information such as spindle, milling spindle, feed axis, cycle time, program/tool no. on one screen.



Alarm Guidance

Presenting an operator alarm's causes and troubleshooting guides and sending an email when the alarm last for a long time.



Maintenance manager

Monitors the status of machine and control elements, and confirms the alarm condition and maintenance schedule for preventative maintenance.

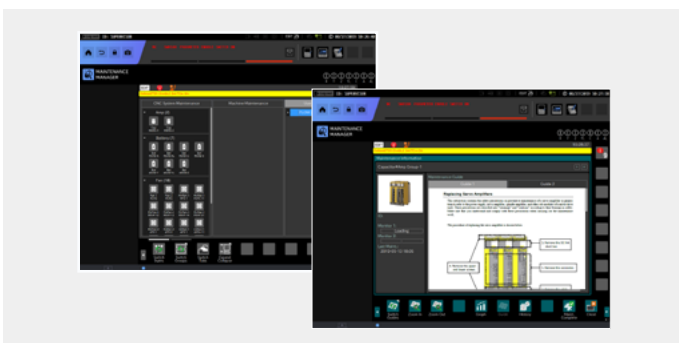

A diverse range of functions and apps are available to meet your needs.

Description	Features	DVF Series	
Hardware	19" Color LCD Screen	●	
	Main RAM memory	4 GB ●	
	Storage Memory	SSD 32GB	●
		SSD 64GB	○
		SSD 128GB	○
	2 point-touch panel port	●	
Windows Embedded standard 7 Operating System (Including the Recovery disk)	●		
Applications	DN Solutions Tool Management	X	
	Collision Protection System (Note: In case of using this application, Main Memory 8GB and SSD 64GB are required.)	○	
	SSD Data server Application (Note: In case of using this application, Data server (for Standard CNC) function can not be used)	●	
	Turncut	X	
	Set and Inspection Application (cooperated with Renishaw)	X	
	File Manager	●	
	FTP Server service	●	
	Smart key access control application	○	
	Memo Application	●	
	Machine status Monitor application	●	
	Alarm guidance application	●	
	Sketch Cycle	X	
	EOP	●	
iHMI basic application	NC Control	●	
	FANUC iHMI	●	
	Manual viewer Application	●	
	Calendar Application	●	
	Browser Application	●	
	Periodic Maintenance Application	●	
	Data Logger Application	●	
	Servo viewer Application	●	

● Standard ○ Optional X N/A

Please contact your DN Solutions representative for detailed machine information.

FANUC 31i/32i PLUS

Fanuc 31i/32i Plus maximizes customer productivity and convenience.

15" Touch screen + New OP

DN Solutions Fanuc 31iB/B5 Plus' operation panel enhances operating convenience by incorporating common-design buttons and layout. It features a Qwerty keyboard for fast and easy data input and operation.

Fanuc 31i/32i Plus

- 15-inch color display
- Intuitive and user-friendly design

USB and PCMCIA card QWERTY keyboard

- EZ-Guide i standard
- Ergonomic operator panel
- 4MB Memory
- Hot keys
- Enhance AICC BLOCK
- Touch pen provided as standard



iHMI touchscreen

iHMI provides an intuitive interface that uses a touchscreen for quick and easy operation.

Range of applications

Providing various applications related to planning, machining, improvement and utility, for customer convenience.

NUMERIC CONTROL SPECIFICATIONS

FANUC

	Item	Specifications	F31iB5 Plus
			DVF Series
Controlled axis	Controlled axes		5 (X,Y,Z,C,A) (X,Y,Z,C,B)
	Simultaneously controlled axes		5 axis
	Additional controlled axis	Add 1 Axis (5th Axis)	●
Data input/output	data server		○
	Memory card input/output		●
	USB memory input/output		●
Interface function	Embedded Ethernet		●
	Fast Ethernet		○
	Enhanced embedded ethernet function		●
Operation	DNC operation	Included in RS232C interface.	●
	DNC operation with memory card		●
Program input	Workpiece coordinate system	G52 - G59	●
	Addition of workpiece coordinate system	G54.1 P1 X 48 (48 pairs)	●
	Tool number command		T4 digits
Feed function	Tilted working plane indexing command	G68.2 TWP	●
	AI contour control II	G5.1 Q_, 1000 Blocks	●
Operation Guidance Function	High smooth TCP		●
	EZ Guide i		●
Setting and display	EZ Operation package		●
	CNC screen dual display function		●
Network	FANUC MTConnect		✳
	FANUC OPC UA		✳
Others	Display unit	15" color LCD with Touch Panel	●
		10240M(4MB)_1000 programs	●
		20480M(8MB)_1000 programs	○
		2560M(1MB)_2000 programs	○
		5120M(2MB)_4000 programs	○
		10240M(4MB)_4000 programs	○
		20480M(8MB)_4000 programs	○

Network: FANUC MTConnect and FANUC OPC UA available.

● Standard ○ Optional ✕ Not Available ✳ Available

EZ WORK

The software developed by DN Solutions's own technology provides numerous functions designed for convenient operation.

EZ work

The EZ work package delivers speed and efficiency. This menu-driven innovation not only helps customers reduce setup times, but also simplifies common tasks and procedures, reducing the potential for errors. EZ work reduces operating time, protects machinery, enhances quality and speeds up maintenance interventions.

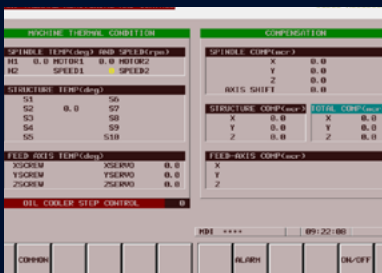

Thermal Compensation

A function to maintain high-precision machining quality by analyzing and correcting the amount of thermal displacement of a structure through a temperature sensor



M/G-Code List

Functional description of M code and G code



Tool Management

Function to manage tool information [Tool information / Tool No. / Tool condition (normal, large diameter, worn / damaged, used for the rst time, manual) / Tool name]

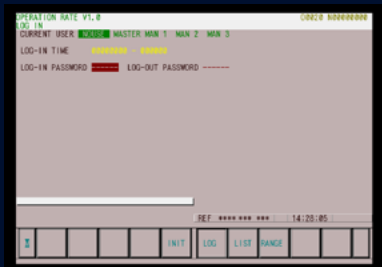

Operation Rate

Machine operation history management function by date based on load



Adaptive Feed Control

Function to control feedrate so that the cutting can be carried out at a constant load

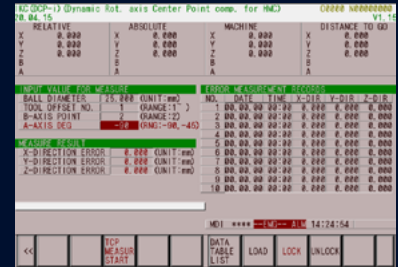

IKC (DCP-I)

The function to compensate the position of the workpiece and the tool tip to be constant regardless of the rotation of the rotating shaft error

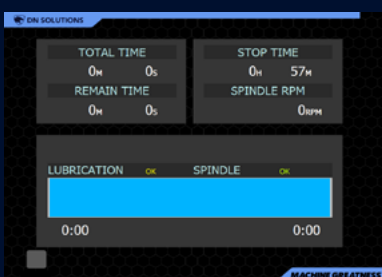

Spindle Warm Up

A function that assists spindle warm-up for spindle life when the spindle has not been used for a certain period of time



ATC Recovery

Function to view detailed info with recommended actions and to perform step-by-step operation manually (when an alarm is triggered during an ATC operation)

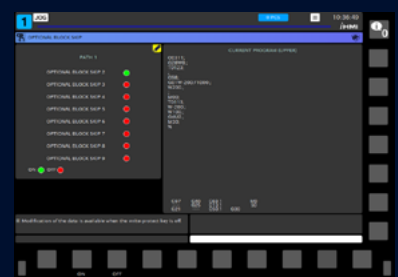

Addition of Optional Block Skip

In addition to the OPTIONAL BLOCK SKIP of the operation panel, the function to skip a specific block selected in the machining program

CONVENIENT OPERATION

Heidenhain TNC640

Superior hardware specifications

The TNC 640 features optimized motion control, short block processing times and special control strategies. Together with its uniform digital design and its integrated digital drive control (including inverters), it enables you to achieve high machining speeds and the best possible contour accuracy.

- 15.6" display
- 21GB Storage memory
- 1024 look ahead blocks
- High user convenience with folder structure data management

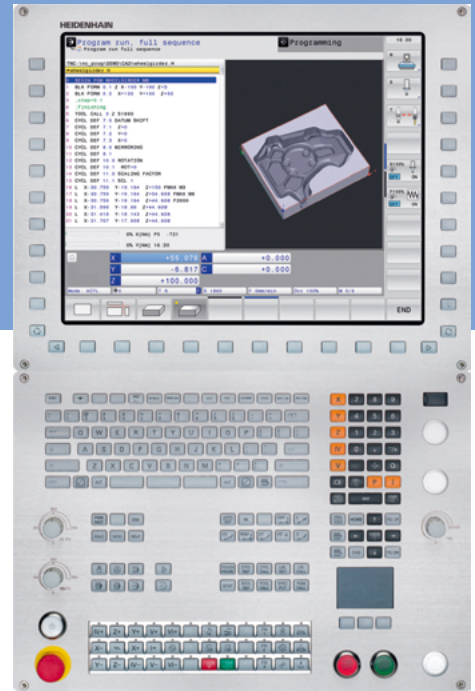

Conversational convenient function

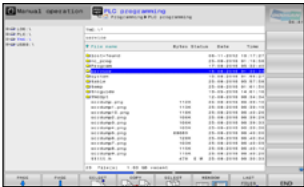

Data are controlled in the folder structure; convenient communication via USB devices



KinematicOpt & KinematicComp option
(Touch probe cycle for automatic measurement)

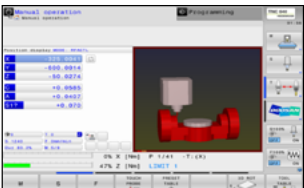

Collision protection system option

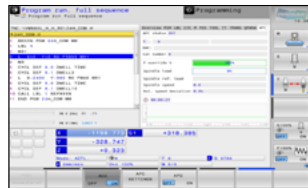

Adaptive feed control option



Various built-in pattern cycles for a wider scope of application (Software standard)

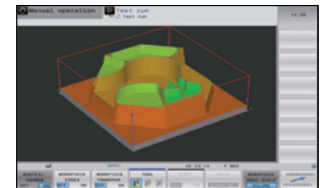

Graphic simulation

NUMERIC CONTROL SPECIFICATIONS



HEIDENHAIN

Item		Specifications	TNC640
			DVF Series
Controlled axis	Controlled axis		5 (X,Y,Z,C,A) (X,Y,Z,C,B)
	Simultaneously controlled axis		5 axis
Data input/output	USB memory input/output		●
Interface function	Embedded ethernet		●
Feed function	Look-ahead	5000 blocks	●
Axis compensation	KinematicsOpt	Automatic measurement and optimization of machine kinematics	●
Collision monitoring	Dynamic collision monitoring (DCM)		○
Network	MTConnect		⊕
Others	Display unit	15" color LCD	●
		15" color LCD with touch panel	○
	Part program storage size & number of registerable programs	21 GB	●

● Standard ○ Optional ✕ Not Available ⊕ Available

CONVENIENT OPERATION

Siemens 840D

15.6" screen + new operation panel

The newly-designed operation panel improves the customer convenience by incorporating and using common-design buttons and layouts, and includes the familiar QWERTY keyboard for fast and easy operation.

- 15.6" display
- 10MB high capacity user memory
- USB & ethernet (standard)
- QWERTY keyboard (standard)
- High-speed calculation and simulation can be fulfilled by improved processor functionality



Conversational convenient function

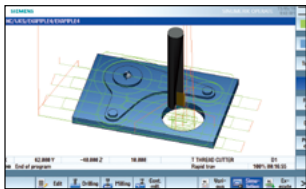

Simulation and machining contour monitoring

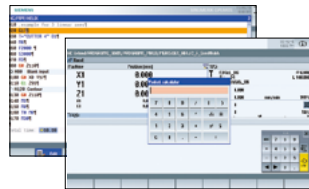

Smart function

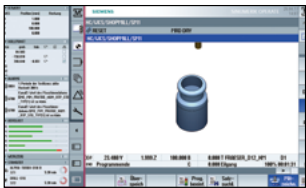

Side screen widget

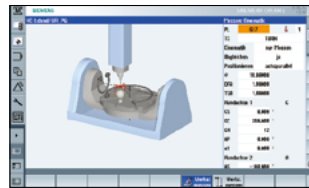

5-axis kinematic measuring cycles

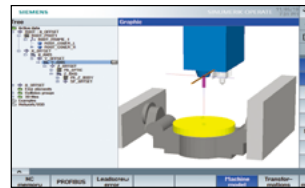

3D collision avoidance and collision avoidance ECO

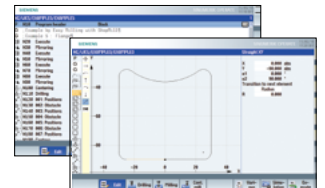

Shop mill part programming

NUMERIC CONTROL SPECIFICATIONS

SIEMENS

	Item	Specifications	S840Dsl
			DVF 8000
Controlled axis	Controlled axes	5 axes	●
	Simultaneously controlled axes	5 axes	●
Data input/output	Memory card input/output	(Local drive)	●
	USB memory input/output		●
Interface function	Ethernet	(X130)	●
Operation	On network drive	(without EES option, Extcall)	●
	On USB storage medium, e.g. memory stick	(without EES option, Extcall)	●
Program input	Workpiece coordinate system	G54 - G57	●
	Addition of workpiece coordinate system	G505 - G599	●
Interpolation & feed function	Advanced surface		●
	Top surface		○
Programming & editing function	Look ahead number of block	S/W version 4.8	1000
	3D simulation, finished part		●
	Simultaneous recording		●
	Measure kinematics		●
Operation guidance function	DXF Reader for PC integrated in SINUMERIK Operate		○
	ShopMill		●
Setting and display	EZ Work		●
	Operation via a VNC viewer		●
Network	MTConnect		⊕
	OPCUA		○
Etc. function	15.6" color display with touch screen		●
	19" color display without touch screen		○
	21.5" color display with touch screen		○
	CNC user memory	10 MB	●
	Expansion by increments	2 ~ 12 MB	○
	Collision avoidance		○
Collision avoidance ECO (machine, working area)		●	

POWER | TORQUE

FANUC

DVF 6500, 8000

SPEED: **12000** r/min

POWER: **22/18.5** kW
29.5/24.8 hp

TORQUE: **229** N·m 169.0 ft-lbs

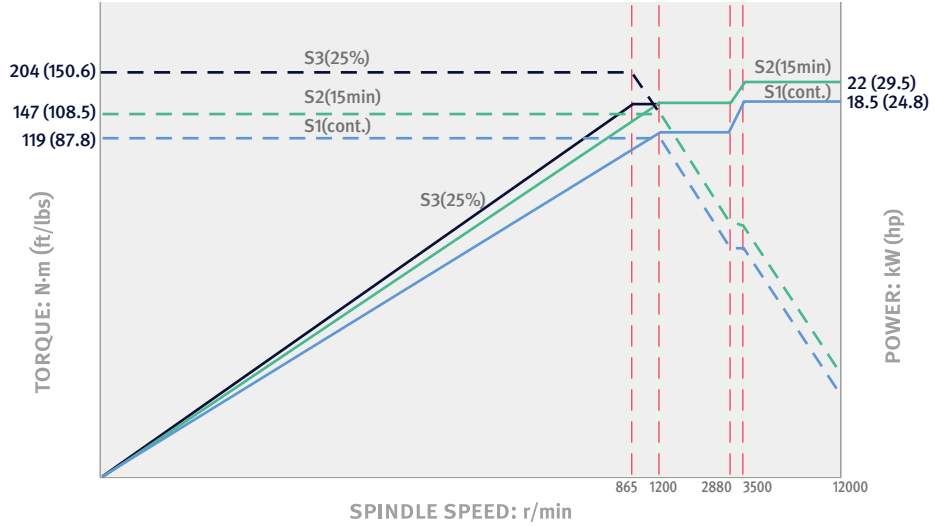

DVF 6500, 8000 option

DVF 6500T, 8000T, 8000T/50

SPEED: **18000** r/min

POWER: **22/18.5** kW
29.5/24.8 hp

TORQUE: **117** N·m 86.3 ft-lbs

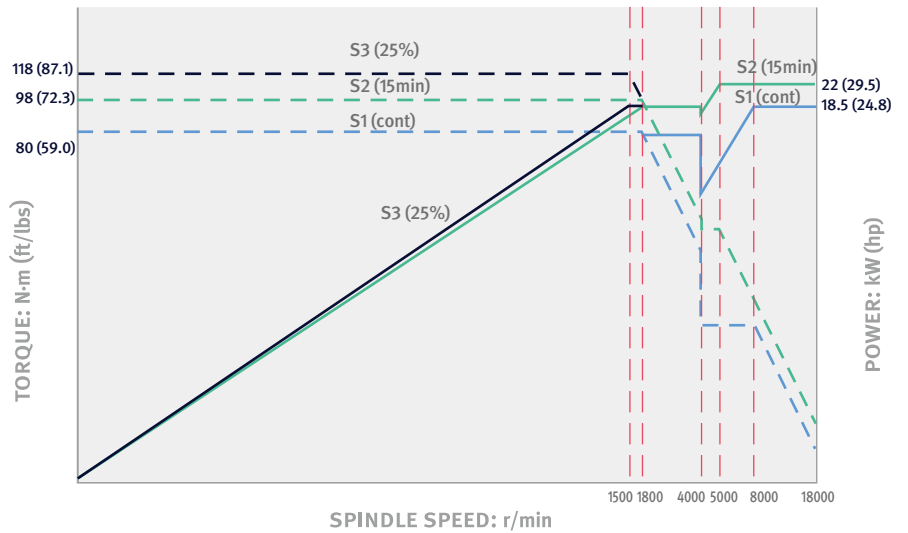

DVF 8000/50, 8000T/50

SPEED: **10000** r/min

POWER: **37/25** kW
49.6/33.5 hp

TORQUE: **488** N·m 360.1 ft-lbs

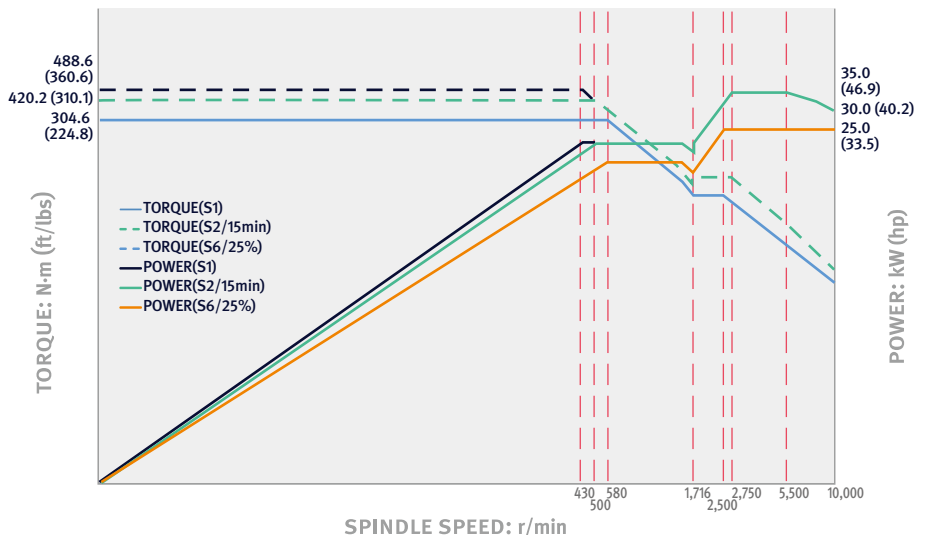

POWER | TORQUE

HEIDENHAIN • SIEMENS

DVF 6500, 8000

SPEED: **12000** r/min

POWER: **30/24** kW
40.2/32.2 hp

TORQUE: **155** N·m
150.6 ft-lbs

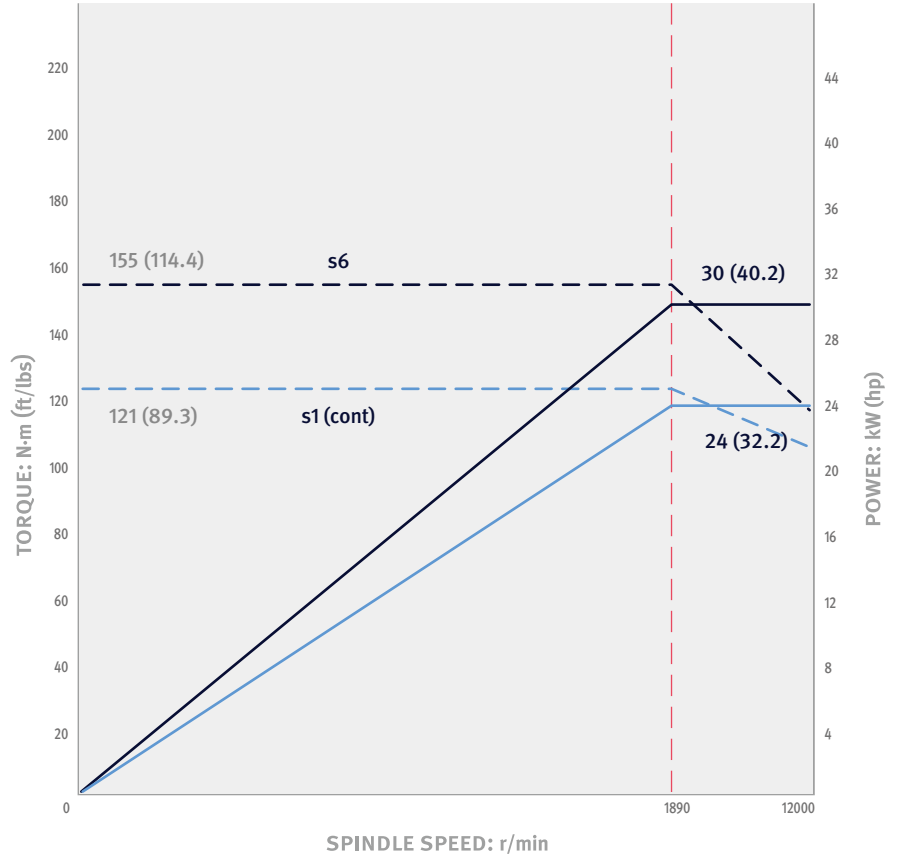

DVF 6500, 8000
DVF 6500T/8000T

SPEED: **18000** r/min

POWER: **30/24** kW
40.2/32.2 hp

TORQUE: **155** N·m
150.6 ft-lbs

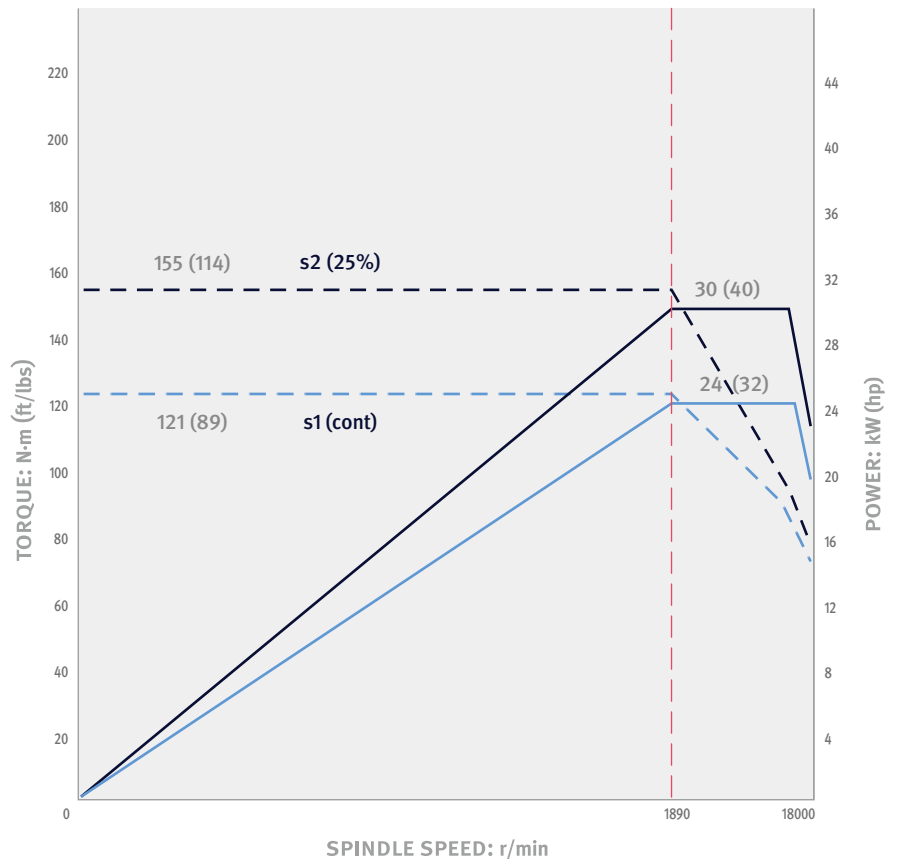

POWER | TORQUE

HEIDENHAIN • SIEMENS

SIEMENS

DVF 8000/50, 8000T/50

SPEED: **10000** r/min

POWER: **37/25** kW
49.6/33.5 hp

TORQUE: **426** N·m
314.6 ft-lbs

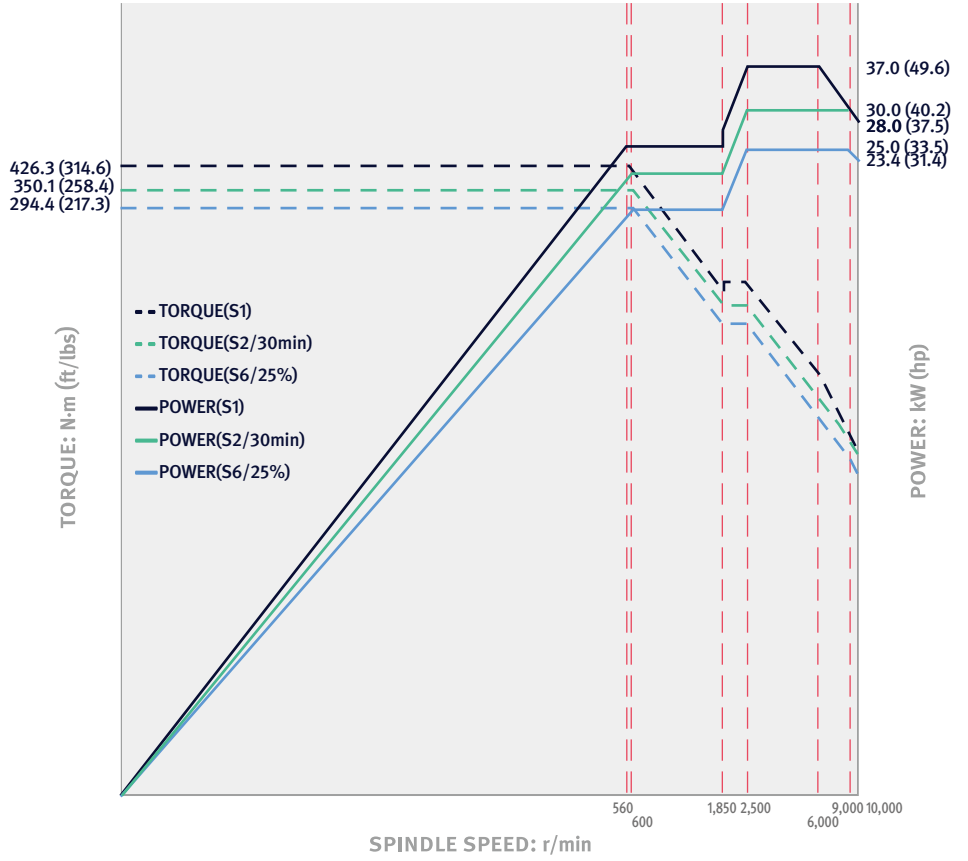

HEIDENHAIN

DVF 6500T/8000T

SPEED: **18000** r/min

POWER: **30/24** kW
40.2/32.2 hp

TORQUE: **155** N·m
114.4 ft-lbs

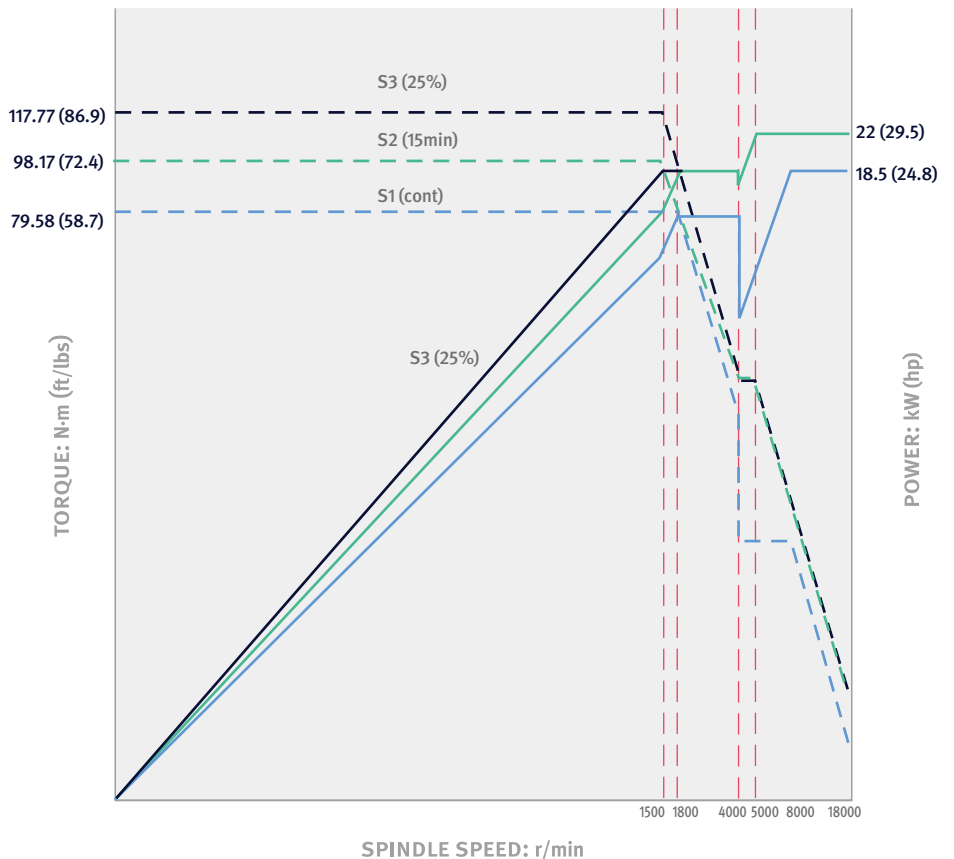

DIMENSIONS

DVF 6500 · 6500T

Units : mm (inch)

DVF 6500

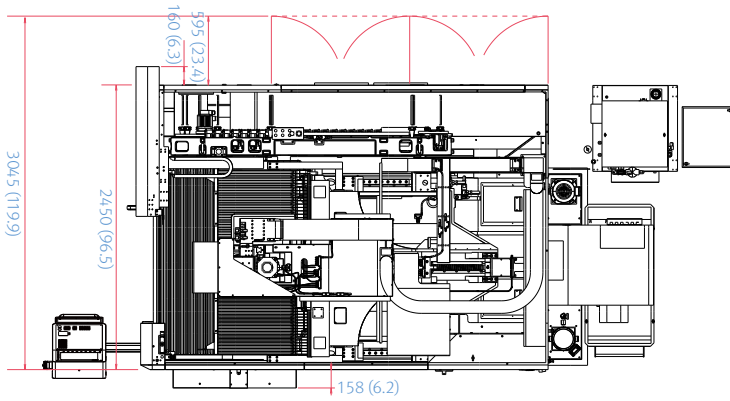

TOP

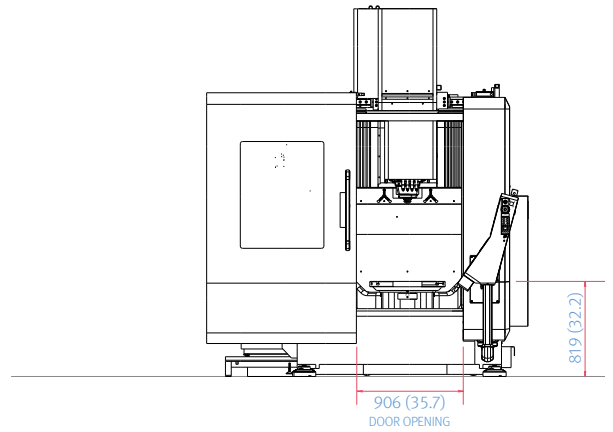

FRONT

DVF 6500T

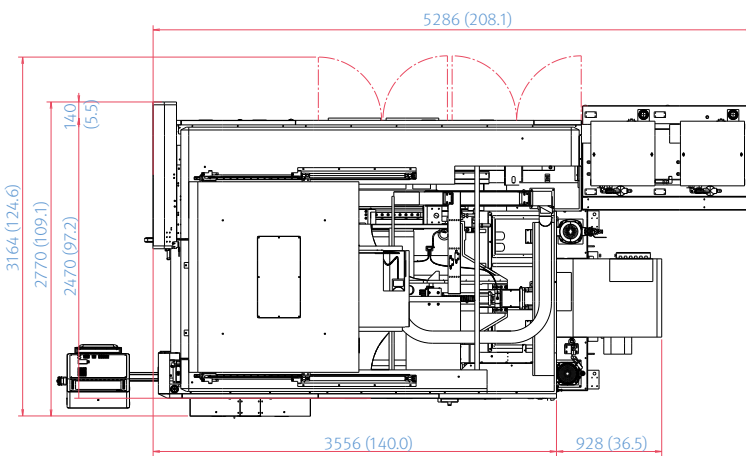

TOP

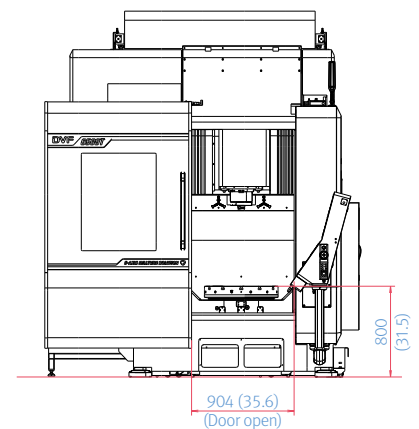

FRONT

*Some peripheral equipment can be placed in other areas

DIMENSIONS

DVF 8000 · 8000T

DVF 8000

Units : mm (inch)

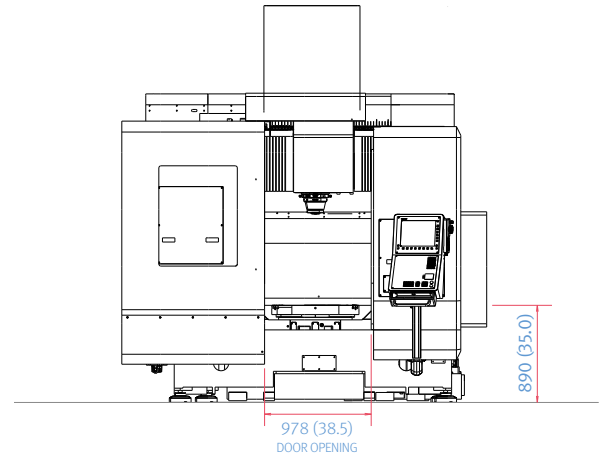
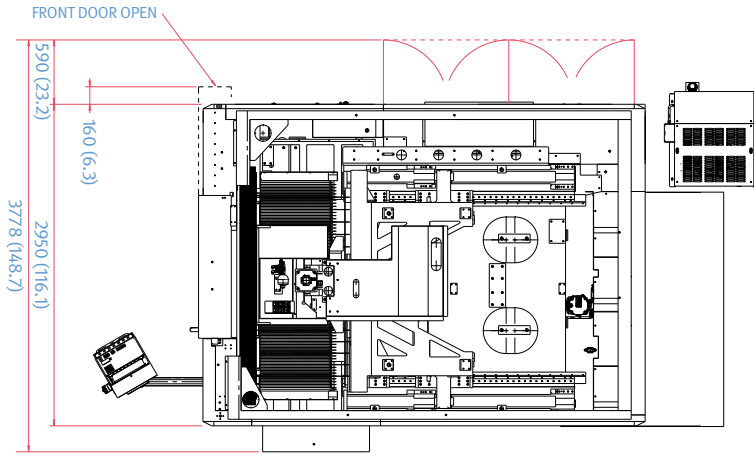

DVF 8000T

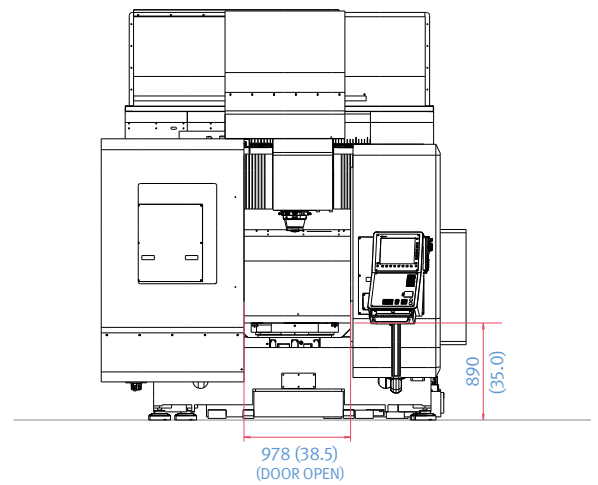
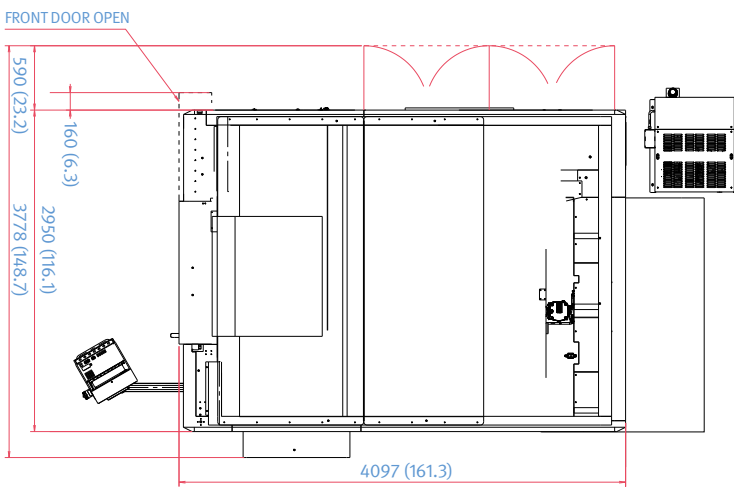

DIMENSIONS

DVF 8000/50 · DVF 8000T/50

DVF 8000/50, DVF 8000T/50

Units : mm (inch)

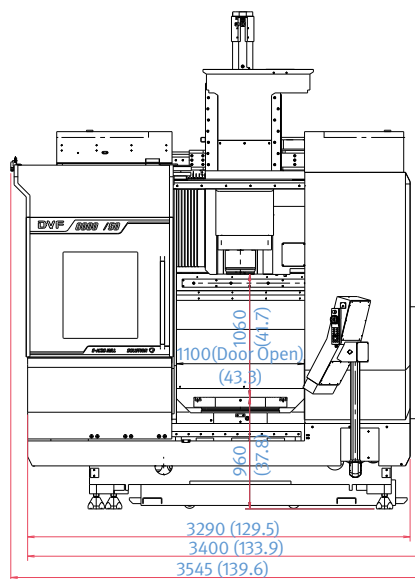
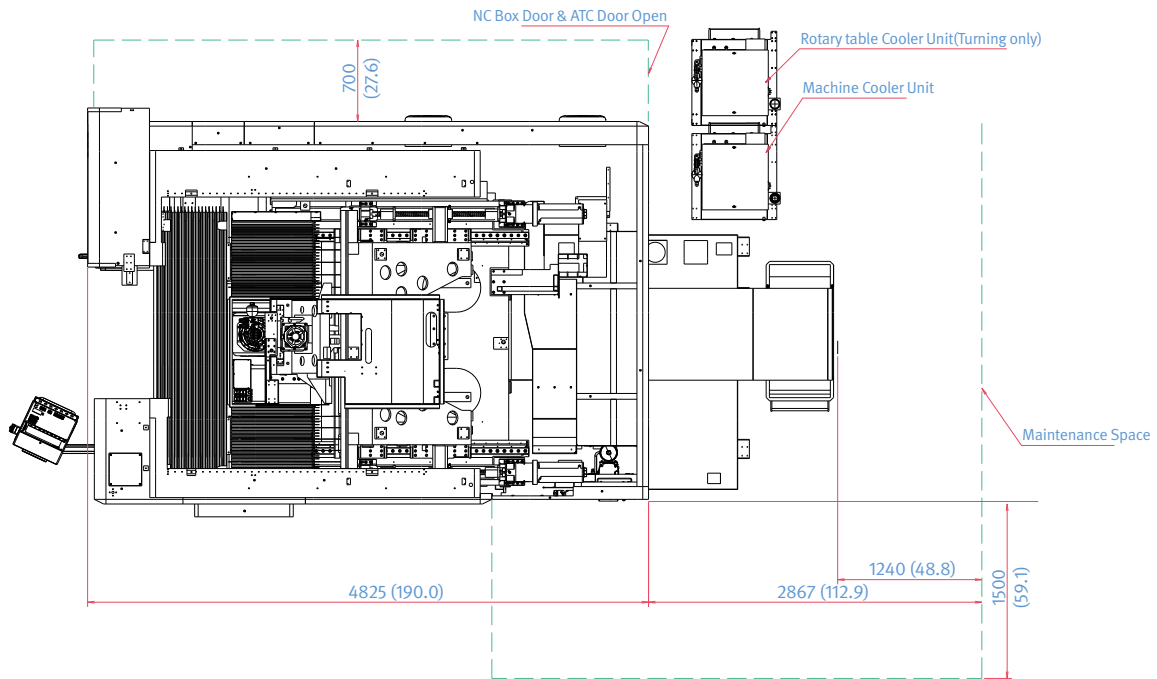

*Some peripheral equipment can be placed in other areas

INTERFERENCE

DVF 6500 · 6500T

Units : mm (inch)

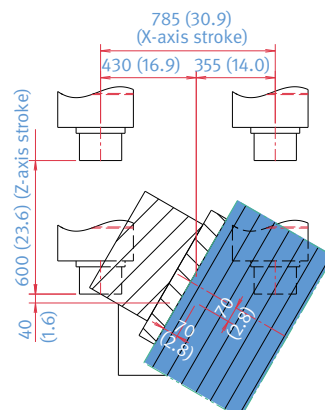
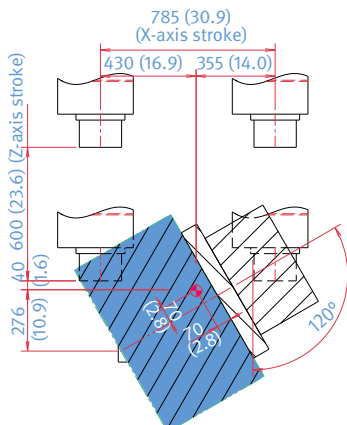
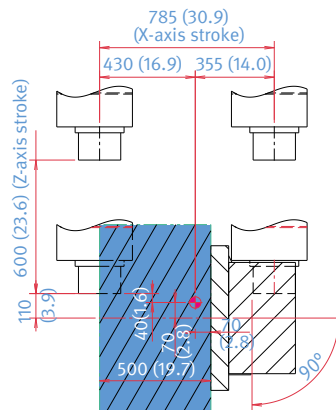
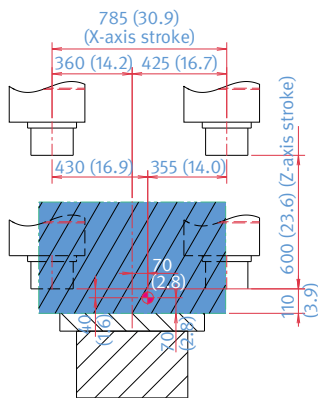
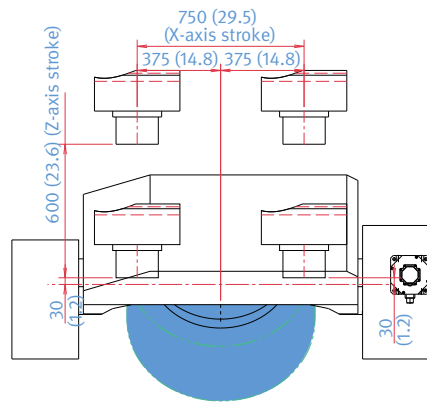
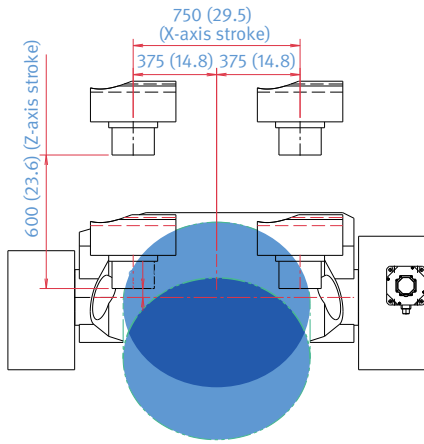
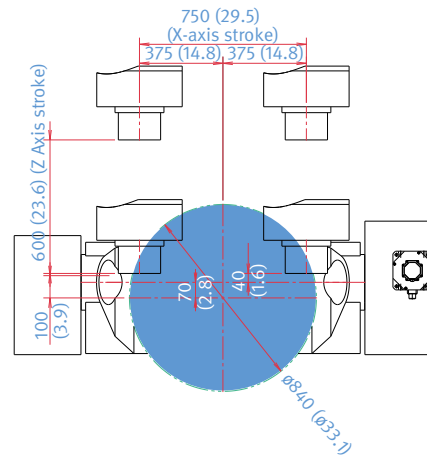
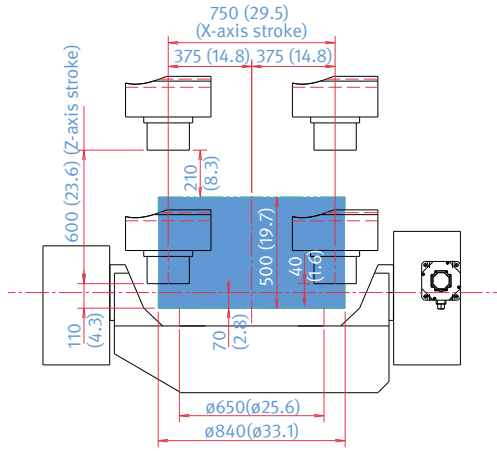

INTERFERENCE

DVF 8000 · 8000T

Units : mm (inch)

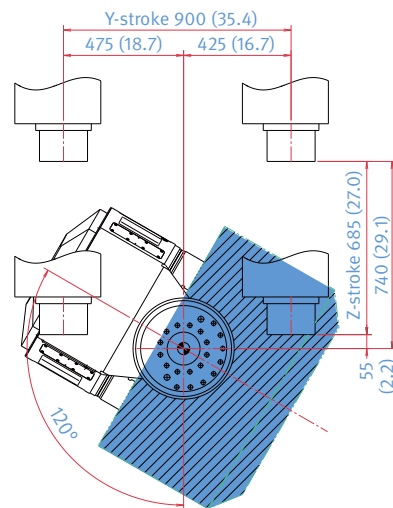
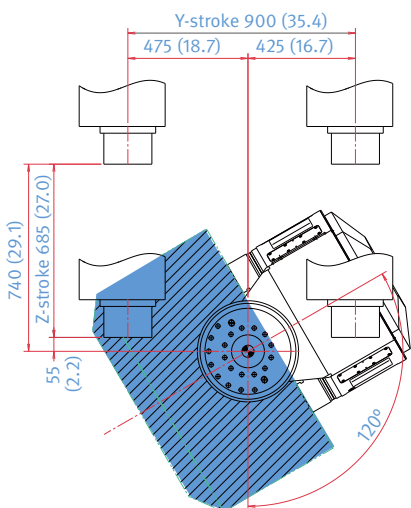
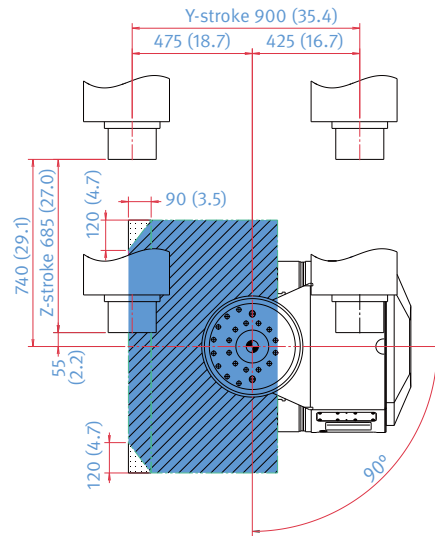
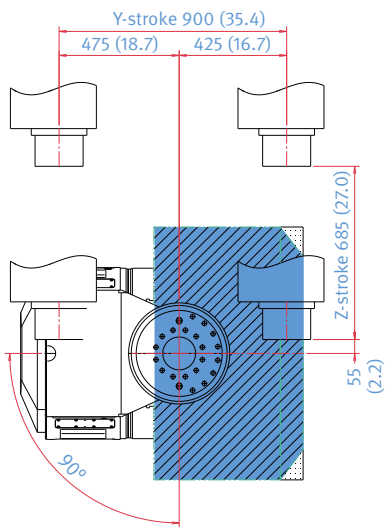
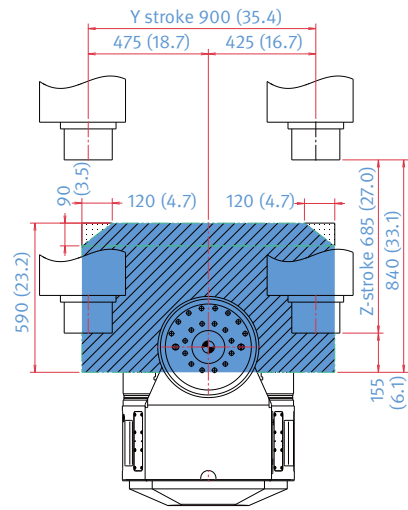
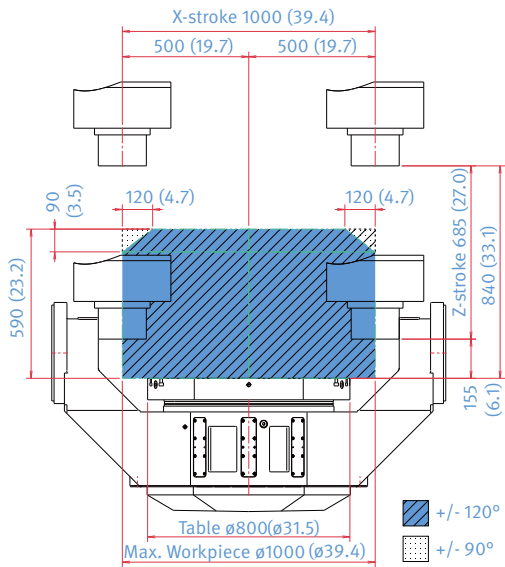

*Some peripheral equipment can be placed in other areas

INTERFERENCE

DVF 8000/50 · DVF 8000T/50

Units : mm (inch)

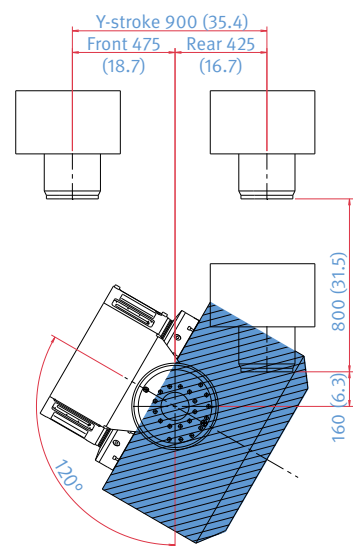
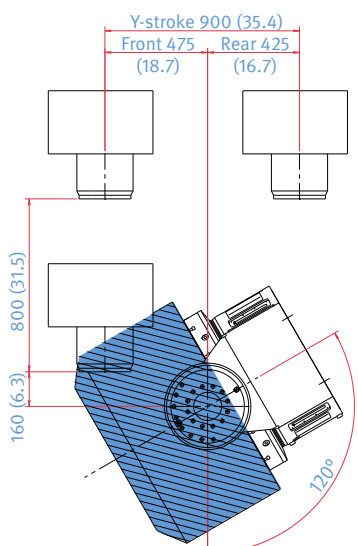
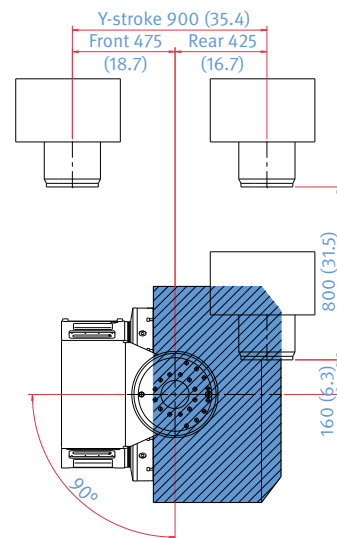
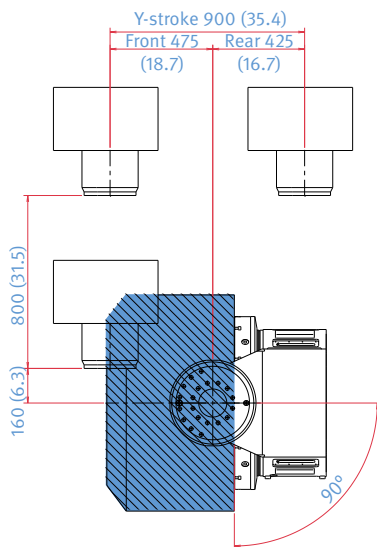
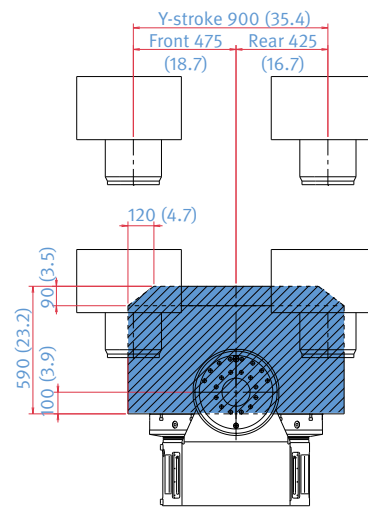
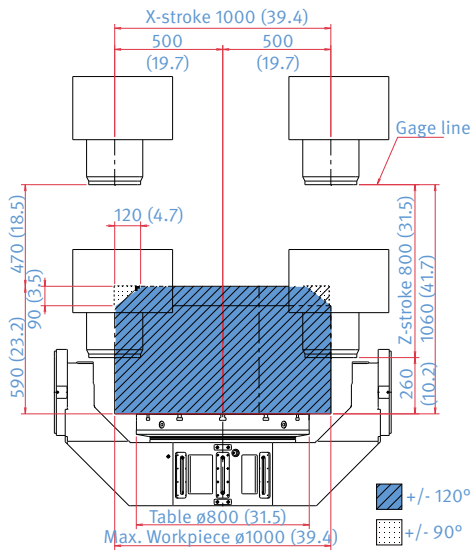

MACHINE SPECIFICATIONS

DVF 6500 · 6500T · 8000 · 8000T

Description			Unit	DVF 6500	DVF 6500 T	DVF 8000	DVF 8000T	DVF 8000/50	DVF 8000T/50	
Travels	Travel distance	X axis	mm (inch)	750 (29.5)		1000 (39.4)		1000 (39.4)		
		Y axis	mm (inch)	785 (30.9)		900 (35.4)		900 (35.4)		
		Z axis	mm (inch)	600 (23.6)		685 (27.0)		800 (31.5)		
		A axis	deg	-120 ~ +120						
		C axis	deg	360						
Table	Table size		mm (inch)	ø650 x 600 (ø25.6 x 23.6)	ø650 x 500 (ø25.6 x 19.7)	ø800 x 680 (ø31.5 x 26.8)	ø800 (ø31.5)	ø800 x 680 (ø31.5 x 26.8)	ø800 (ø31.5)	
	Max. workpiece size		mm (inch)	ø840 x H500 (ø33.1 x H19.7)		ø1000 x H590 (ø39.4 x H23.2)		ø1000 x H590 (ø39.4 x H23.2)		
	Max. workpiece weight		kg (lb)	600 (Tandem:1,000) (1322.8)	500 (1102.3)	1400 (3086.4)	700 (1543.2)	1400 (3086.4)	700 (1543.2)	
Spindle	FANUC	Max. spindle speed	r/min	12000 {18000}	18000	12000 {18000}	18000	10000		
		Max. spindle power (S3/Cont.)	kW (Hp)	22/18.5 (29.5/24.8) (29.5/24.8 (39.6/33.3))					37/25 (49.6/33.5)	
		Max. spindle torque	N · m (ft-lbs)	229 {221} (169.0 {163.1})	221 (163.1)	229 {221} (169.0 {163.1})	221 (163.1)	488 (360.1)		
	HEIDENHAIN SIEMENS	Max. spindle speed	r/min	12000 {18000}	18000	12000 {18000}	18000	10000		
		Max spindle power (S6 40%/Cont.)	kW (Hp)	30/24 {30/24} (40.2/32.2 {40.2/32.2})	30/24 (40.2/32.2)	30/24 {30/24} (40.2/32.2 {40.2/32.2})	30/24 (40.2/32.2)	37/25 (49.6/33.5)		
		Max. spindle torque	N · m (ft-lbs)	155 {155} (114.4 {114.4})	155 (114.4)	155 {155} (114.4 {114.4})	155 (114.4)	426 (314.4)		
Feedrate	Rapid traverse	Xaxis	m/min (ipm)	45 (1771.7)					36	
		Yaxis	m/min (ipm)	45 (1771.7)					36	
		Zaxis	m/min (ipm)	45 (1771.7)					30	
		Baxis	r/min	25					25	
		Caxis	r/min	50	1000	60	600	60	600	
Automatic tool changer	Tool type	Tool shank	-	ISO#40	HSK-T63	ISO#40	HSK-T63	ISO#50	HSK-T100	
	Tool capacity		ea	40 {60, 120}	60 {120}	40 {60, 120}	60 {120}	40 {60}	40 {60}	
	Max. tool dia.	Continous	mm (inch)	75 (3.0)					125 (4.9)	
		Without adjacent tools	mm (inch)	125 (4.9)					220 (8.7)	
	Max. tool length		mm (inch)	300 (11.8)					320 (12.6)	
	Max. tool weight		kg (lb)	8 (17.6)					15 (0.6)	
	Tool to Tool		sec	1.3					2.5	
Tank capacity	Coolant tank		L (gal)	650 (171.7)		800 (211.4)		800 (211.4)		
Machine dimensions	Height		mm (inch)	3100 (122)	3255 (128.1)	3670 (144.5)		4330 (170.5)		
	Length		mm (inch)	3700 (145.7)	3700 (145.7)	4097 (161.3)		4825 (190.0)		
	Width		mm (inch)	2450 (96.5)	2450 (96.5)	2950 (116.1)		3400 (133.9)		
	Weight		kg (lb)	14500 (31966.6)	12500 (492.1)	25000 (55114.8)		25000 (55114.8)		
Control	NC system		-	CUFOS, HEIDENHAIN TNC 640, SIEMENS S840D, FANUC 31i/32i Plus						

The DN Solutions promise, MACHINE GREATNESS, has two important meanings. The first is simple: DN Solutions makes great machines. The second is a challenge to our end-users. With a product line that is this comprehensive, accurate and reliable, we equip our customers to machine greatness. The big question: **Why should you choose DN Solutions over other options?**

Here's why...



**MACHINE
GREATNESS™**



WHAT YOU MAKE AND HOW YOU MAKE IT MATTERS—SO MAKE IT GREAT WITH DN SOLUTIONS.

UNBEATABLE MACHINES

You won't find a more comprehensive range or a better combination of value, performance and reliability anywhere else.

ROBUST PRODUCT LINE

We offer an impressive range of machine models and hundreds of configurations. Whatever your machining needs and requirements, there's a DN Solutions for you.

READILY AVAILABLE - ANYWHERE IN THE WORLD

Machining centres (including 5-axis machines), lathes, multi-tasking turning centres and mill-turn machines, and horizontal borers with best-in-class specifications are all available...ready to install.

EXPERT SERVICE

Our dedicated, experienced and knowledgeable team is totally committed to improving your productivity, growth and success.

RESPONDING TO CUSTOMERS ANYTIME, ANYWHERE

DN Solutions Global Network

DN Solutions provides systems-based professional support services, before and after the machine tool sale, by responding quickly and efficiently to customers. By supplying spare parts, product training, field service and technical support, we provide the expert care, attention and assistance our customers expect from a market leader.

Global sales and service support network		51	Technical centers Technical center, Sales support, Service support, Parts support
4	Corporations	200	Service posts
156	Dealer networks	3	Factories



CUSTOMER SUPPORT AND SERVICES

We're there for you whenever you need us.

We help our customers operate at maximum efficiency by providing them with a range of tried, tested and trusted services - from pre-sales consultancy to post-sales support.



Field services

- On-site service
- Machine installation and testing
- Scheduled preventive maintenance
- Machine repair service



Parts supply

- Supplying a wide range of original DN Solutions spare parts
- Parts repair service



Training

- Programming, machine setup and operation
- Electrical and mechanical maintenance
- Applications engineering



Technical support

- Supports machining methods and technology
- Responds to technical queries
- Provides technical consultancy



dn-solutions.com

Head Office

22F T Tower, 30, Sowol-ro 2-gil
Jung-gu, Seoul, Korea, 04637

Tel: +82-2-6972-0370/0350
Fax: +82-2-6972-0400

DN Solutions America

19A Chapin Road, Pine Brook
New Jersey 07058, United States

Tel: +1-973-618-2500
Fax: +1-973-618-2501

DN Solutions Europe

Emdener Strasse 24, D-41540
Dormagen, Germany

Tel: +49-2133-5067-100
Fax: +49-2133-5067-111

DN Solutions India

No.82, Jakkuar Village
Yelahanka Hobli, Bangalore-560064

Tel: + 91-80-2205-6900
E-mail: india@dncompany.com

DN Solutions China

Room 101,201,301, Building 39 Xinzhuan
Highway No.258 Songjiang District
China Shanghai (201612)

Tel: +86 21-5445-1155
Fax: +86 21-6405-1472

Sales inquiry

sales@dncompany.com

* For more details, please contact DN Solutions.

* Specifications and information contained within this catalogue may be changed without prior notice.